

7716 192 041

Transmitter 8716 106 6700

Receiver 8716 106 6690

DT20RF PROGRAMMER

7 Day

Radio frequency controlled room thermostat with twin channel digital programmer

FOR GREENSTAR Si MODELS

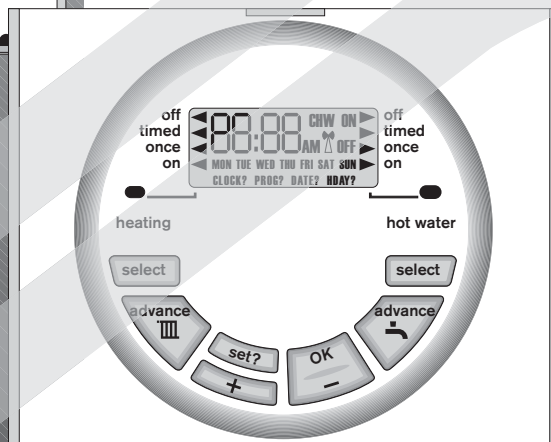
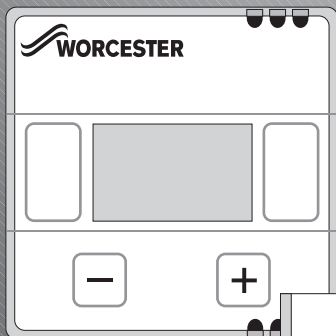

 **WORCESTER**
Bosch Group

INSTRUCTION MANUAL
FITTING & OPERATING INSTRUCTIONS

CONTACT INFORMATION

WORCESTER BOSCH:

TECHNICAL: 08705 266241
SERVICE: 08547 256206
SPARES: 01905 752571
LITERATURE: 01905 752556
TRAINING: 01905 752526
SALES: 01905 752640
WEBSITE: www.worcester-bosch.co.uk

MANUAL INFORMATION

PLEASE READ THESE INSTRUCTIONS CAREFULLY BEFORE STARTING

THESE INSTRUCTIONS ARE APPLICABLE TO THE WORCESTER BOSCH MODEL(S) STATED ON THE FRONT COVER OF THIS MANUAL ONLY AND MUST NOT BE USED WITH ANY OTHER MAKE OR MODEL

THE INSTRUCTIONS APPLY IN THE UK ONLY AND SHOULD BE FOLLOWED EXCEPT FOR ANY STATUTORY OBLIGATION

IF YOU ARE IN ANY DOUBT CONTACT WORCESTER BOSCH TECHNICAL HELPLINE

THIS ACCESSORY MUST BE FITTED BY A COMPETENT PERSON. FAILURE TO COMPLY COULD LEAD TO PROSECUTION.

LEAVE THESE INSTRUCTIONS WITH THE USER OR AT THE APPLIANCE.

ABBREVIATIONS:

CH Central Heating

HW Domestic Hot Water

RF Radio Frequency

DLS Day Light Saving

BST British Summer Time

GMT Greenwich Mean Time

C Celcius

m Metre

IP Ingress Protection

V Volts

mA MilliAmps

DEFINITIONS (DLS/BST):

Summer period begin: Last Sunday in March at 1:00 AM GMT (Clock put forward by 60 minutes)

Summer period end: Last Sunday in October at 2:00 AM GMT (Clock put back by 60 minutes)

SYMBOLS:

 Central Heating

 Domestic Hot Water

 Radio Frequency (RF) transmitter

CONTACT & MANUAL INFORMATION

FITTING & OPERATING INSTRUCTIONS FOR WORCESTER BOSCH
DT20RF PROGRAMMER
8-716-106-659 issue a (08.04) UK

**WORCESTER**
Bosch Group

CONTENTS

ACCESSORY INFORMATION

GENERAL INFORMATION	2
TECHNICAL DATA	3

INSTALLATION & COMMISSIONING

FITTING THE DT20	4
SETTING THE RADIO LINK	5
TRANSMITTER LOCATION, CLEARANCES & FIXING	6

USER INSTRUCTIONS

TRANSMITTER OPERATING CONTROLS	7
RECEIVER OPERATING CONTROLS	8
RECEIVER PRE-SET PROGRAMS	9
RECEIVER SETTING PROGRAMS	
Setting CH Mon-Fri • Setting HW Mon-Fri	10
Setting individual weekdays	11
Setting CH Sat-Sun • Setting HW Sat-Sun	12
Setting individual weekend days	13
RECEIVER SETTING HOLIDAYS	14
RECEIVER SETTING THE CLOCK	15
RECEIVER SETTING THE DATE	16
BATTERY REPLACEMENT	17

SERVICING & SPARES

MAINTENANCE & SPARES	18
----------------------	----

CONTENTS

ACCESSORY
INFORMATION

INSTALLATION &
COMMISSIONING

USER
INSTRUCTIONS

SERVICING
& SPARES

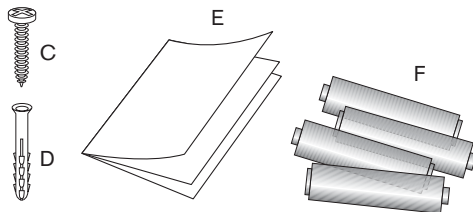
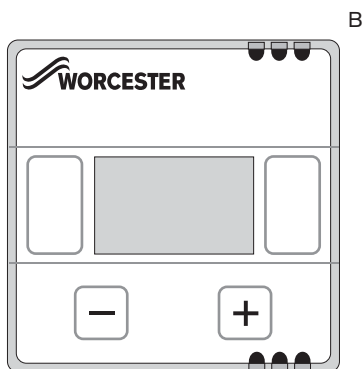
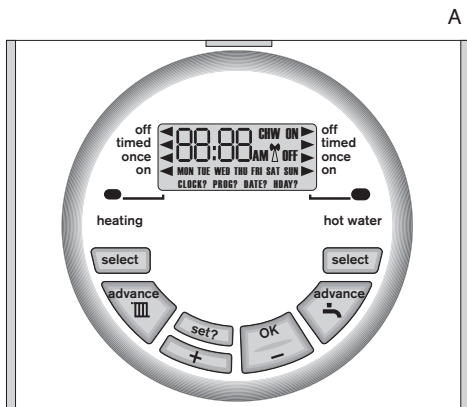

GENERAL INFORMATION

STANDARD PACKAGE:

- A - Programmer/ RF receiver
- B - Remote RF transmitter
- C - Screws (x2)
- D - Wall Plugs (x2)
- E - Instructions
- F - Batteries (x4)

SPECIFICATIONS:

Receiver:

- Twin channel programmer for CH & DHW mounted into the boiler fascia
- 7 day programmer
- 3 on/off periods per day
- Automatic BST settings
- Pre-programmed on/off periods
- Dedicated advance buttons
- 12 or 24 hour back-lit digital display
- Holiday function
- Pre-wired with PCB connector

Transmitter:

- Remote RF Transmitter to control CH temperature
- 4 AA alkaline 1.5V batteries included
- Low battery warning
- Max. signal range approx. 25 metres (range may decrease according to the building construction).

TECHNICAL DATA

DESCRIPTION	UNITS	DT20 Receiver
Dimensions	mm	-
Electrical supply	-	24v DC <65mA
Ambient operating temperature	°C	0 to +50
Humidity operating range	% non-condensing up to 45°	30 - 95
Class of protection	-	II
Degree of protection	IP	24
Accuracy @ 25°C	sec/day	<±1
Battery life	years	10
Battery backup time & date	years min.	10
Shortest switching period	minutes	1
DHW & CH On/Off periods	number	3
DHW & CH Programs	days	7

ACCESSORY
INFORMATION

Related Standards:

BS EN60730-1:2001

BS EN60730-2-7:1992

Electro Magnetic Compatibility and Radio Spectrum Matters (ERM); Short Range Devices (SRD) ETSI EN 300 220-1

EC Directives:

European Union Law Directive 2000/84/EC

Low Voltage Directive (73/23/EEC)

Electro Magnetic Compatibility Directive (89/336/EEC)

CE Marking Directive (93/68/EEC)

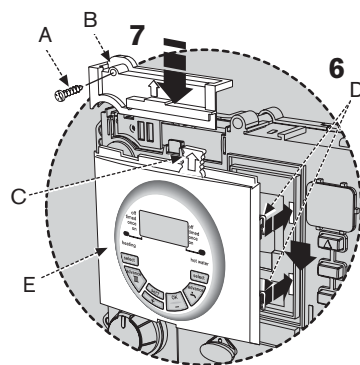
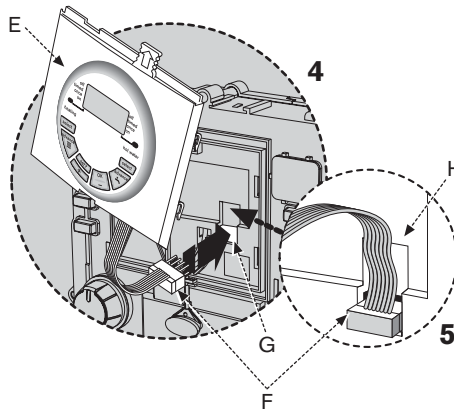
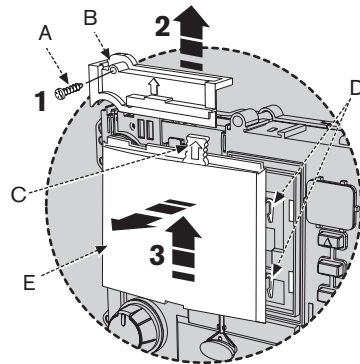

FITTING THE RECEIVER



DANGER - 24V & 230V: DO NOT TOUCH THE ELECTRICAL COMPONENTS OR CIRCUITS.

CAUTION: ISOLATE THE MAINS ELECTRICITY SUPPLY BEFORE STARTING ANY WORK AND OBSERVE ALL RELEVANT SAFETY PRECAUTIONS.

OBSERVE ELECTRONIC STATIC DISCHARGE PRECAUTIONS. DO NOT TOUCH THE PCB CIRCUITS

- ▶ **Important: Switch off boiler**
- ▶ Remove boiler outer casing and control panel fascia to gain access to the heatronic control panel
- 1 Release securing screw (A)
- 2 Pull cover panel (B) upwards to remove
- 3 Grip tab (C), pull upwards to disengage clips (D) and pull forwards to remove blanking plate (E) or existing programmer
- 4 Align connector pins (F) into receptors (G) in the PCB and push fully home
- 5 Feed the ribbon cable (G) into recess (H)
- 6 Align programmer (E) and locate clips (D), push into slots then downwards to secure
- 7 Locate cover panel (B) and secure with screw (A)
- ▶ Replace fascia cover and outer casing before switching on the electricity supply and boiler
- ▶ Switch boiler on when completed.
- ▶ Refer to 'USERS INSTRUCTIONS' section for details of pre-set and setting programs.

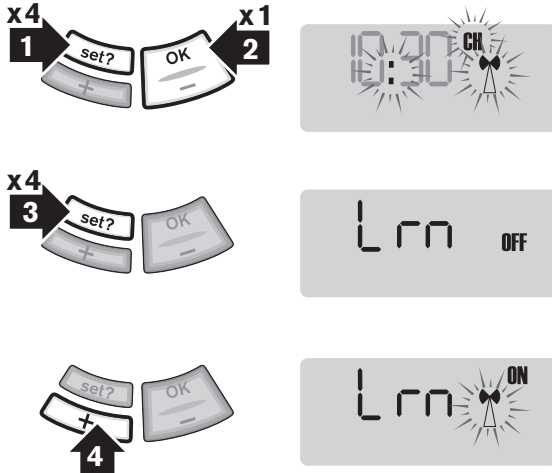

SETTING THE RADIO LINK

Receiver set up:

- ▶ The colon, CH and antenna symbols should flash on the display
- 1 Press the 'set?' button 4 times
- 2 Press the 'OK' button once
- 3 Press the 'set?' button 4 times; 'Lrn' and 'OFF' should be displayed
- 4 Press the '+' button so the display shows 'ON' and a flashing antenna symbol. The learn mode is now ready to receive a signal from the transmitter during the next 2 minutes.

Transmitter set up:

The transmitter must be at least 1 metre away from the receiver before starting this procedure:

- 5 Slide open battery compartments (B)
- 6 Remove insulator strips (C)
- 7 Replace the **right hand** battery compartment (B) **first** followed by the left hand battery compartment

The display (D) then shows the room temperature and automatically transmits a signal to the receiver unit in the boiler to establish a radio link.

- 8 When a radio link has been established the display reverts back to normal operation with the antenna symbol shown

To re-establish the radio link; open both battery trays until the transmitter display goes blank, repeat steps 1 to 4 then step 7 to transmit a set up signal to the receiver. Repeat this procedure until a link has been established.

If the radio link is lost the antenna, colon and CH symbols flash on the receiver display. The program defaults to manual mode. Press the 'OK' button to override and switch the heating ON, press again to switch OFF.

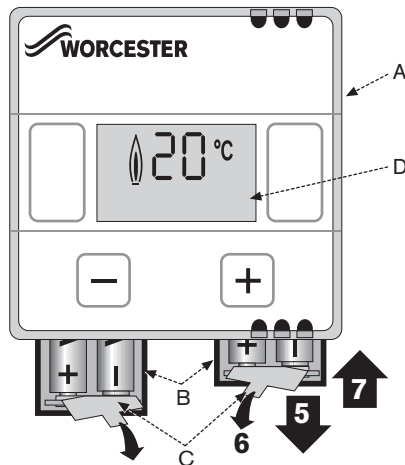

INSTALLATION & COMMISSIONING



1

TRANSMITTER LOCATION CLEARANCES & FIXING

Transmitter location:

1 Position the transmitter (A) as close to the main living area as possible onto a flat inside wall, approx. 1.5m (5') above the floor within max. signal range of the appliance receiver.

Keep the transmitter away from:

- light and heat sources
- enclosures and curtains
- direct draughts, including fans, air vents, windows and doors
- damp and condensation

Replacing a mains wired unit:

Isolate the main electric supply. Refer to the manufacturer's instructions to remove the unit. Isolate the existing wiring and make electrically safe.

Transmitter clearances:

See diagram opposite for minimum area required for operation.

Transmitter fixing:

SAFETY: All relevant safety precautions must be undertaken. Protective clothing, footwear, gloves and safety goggles must be worn as appropriate.

CAUTION: Ensure there are no pipes, electric cables or other hazards before drilling.

- 2 Loosen screw (C) on transmitter to remove the baseplate (B)
- 3 Hold baseplate (B) level to mark securing points (D) and remove baseplate (B)
- 4 ▶ Drill holes to marks
 - ▶ Fit one wall plug into each hole
 - ▶ Reposition baseplate (B), check level and secure with screws supplied
 - ▶ Refit the transmitter to the baseplate (B) and tighten screw (C) to secure.

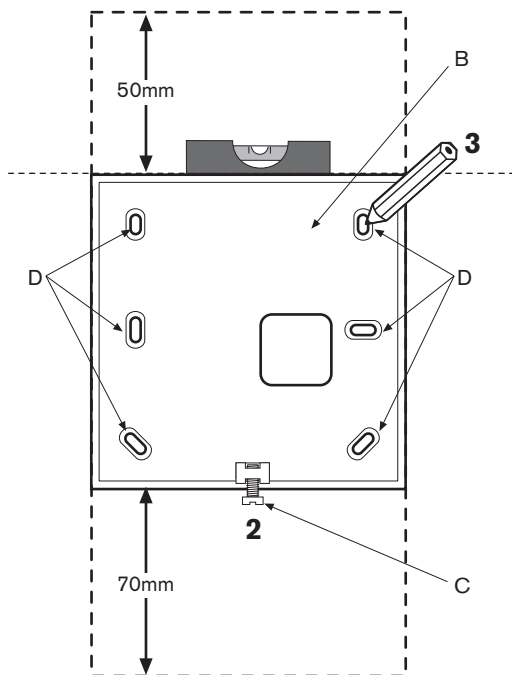

6

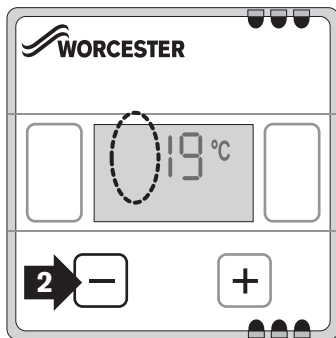
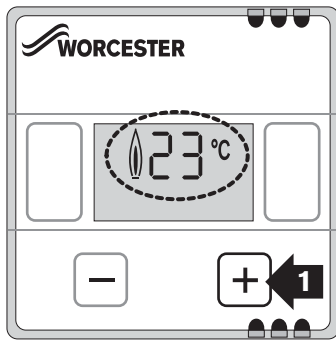

TRANSMITTER OPERATING CONTROLS

The flame symbol indicates:

- 🔥 Flame on = heating demand ON
- Flame off = heating demand OFF

To change the room temperature:

Note: the following only occurs during a timed on period and has no effect when the receiver is in an off setting.

- 1** To increase the room temperature: press the '+' button until the required temperature is displayed
- 2** To decrease the room temperature: press the '-' button until the flame symbol is no longer displayed

After 5 seconds the display reverts back to the actual room temperature.

USER
INSTRUCTIONS

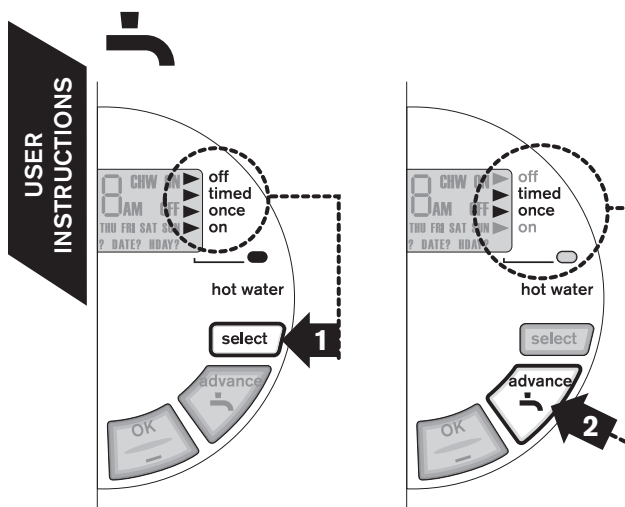
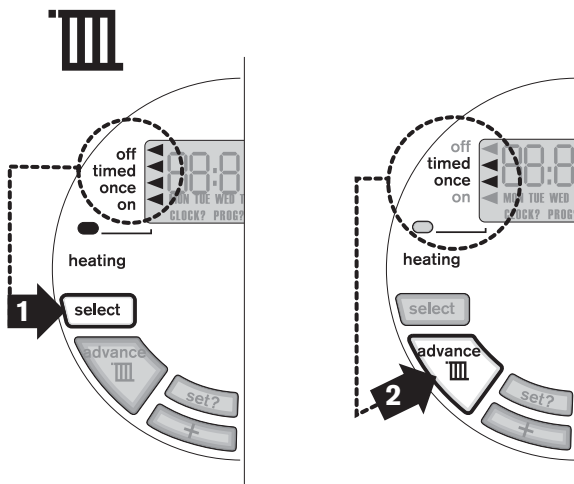

RECEIVER OPERATING CONTROLS

Central heating:

1 Press 'select' button to choose:

off ◀ = constantly OFF

timed ◀ = up to 3 ON and 3 OFF time periods as program

once ◀ = ON from 1st ON until 3rd OFF time period as program

on ◀ = constantly ON

2 Press 'advance' button:

ON = heating light on (heating demand stays on until the next OFF time period)

OFF = heating light off (heating demand stays off until the next ON time period)

Note: 'advance' has no effect with the constant on or off selected on the receiver or when there is no demand from the transmitter.

Hot Water:

1 Press 'select' button to choose:

▶ **off** = constantly OFF

▶ **timed** = up to 3 ON and 3 OFF time periods as program

▶ **once** = ON from 1st ON until 3rd OFF time period as program

▶ **on** = constantly ON

2 Press 'advance' button:

ON = hot water light on (hot water stays on until the next OFF time period)

OFF = hot water light off (hot water stays off until the next ON time period)

Note: 'advance' will not function with constant on or off selected.

RECEIVER PRE-SET PROGRAMS

Note: The clock time is pre-programmed and should not require adjustment.

if you need to restore the factory pre-set program times then:

Press the '-' and '+' buttons together to restore the default program times to those shown in the table opposite.

The default ON/OFF periods pre-programmed for CH and DHW are shown in the table opposite.

Note: two ON/OFF periods can be used instead of 3 by setting the 2nd ON & OFF periods to 12.00 as shown in the default program table.

One ON/OFF period can be achieved by setting the 2nd and 3rd ON & OFF periods to the same time.

See 'RECEIVER SETTING PROGRAMS' in the USER INSTRUCTIONS section if changes are required to the clock time or pre-programmed settings.

	1st ON	1st OFF	2nd ON	2nd OFF	3rd ON	3rd OFF
Central Heating:						
<i>MON to FRI</i>						
Time	6:30	8:30	12:00	12:00	16:30	22:30
<i>SAT & SUN</i>						
Time	7:00	9:00	12:00	12:00	16:00	23:00
Hot Water:						
<i>MON to FRI</i>						
Time	6:30	8:30	12:00	12:00	16:30	22:30
<i>SAT & SUN</i>						
Time	7:00	9:00	12:00	12:00	16:00	23:00

USER
INSTRUCTIONS

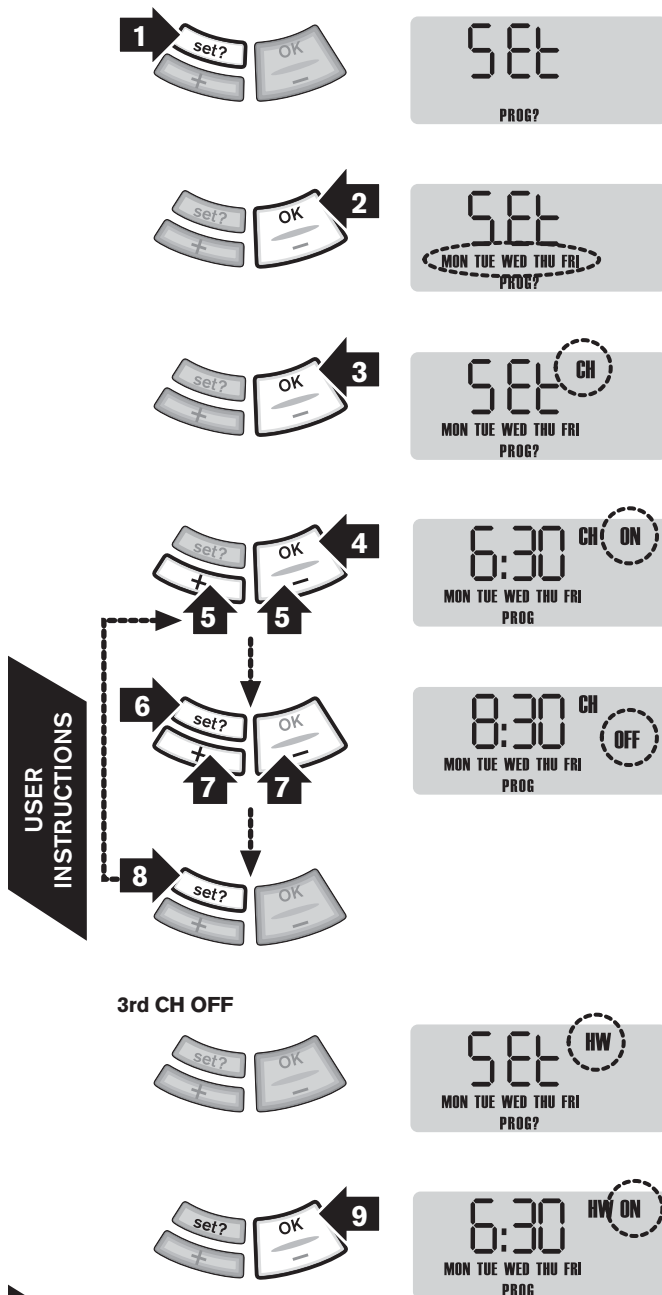

RECEIVER SETTING PROGRAMS

Setting CH MON - FRI:

- 1 Press 'set?' until 'SET' & 'PROG?' are shown in the display
- 2 Press 'OK' to enter program
- 3 Press 'OK' to select MON-FRI
- 4 Press 'OK' to select CH

Note: speed up the display by holding down the '+' or '-' buttons.

- 5 Press '+' or '-' to change the ON time
- 6 Press 'set?' to set the ON time and select the OFF time
- 7 Press '+' or '-' to change the OFF time
- 8 Press 'set?' to set the OFF time and select the next ON time

Repeat operations 5 to 8 to set the 2nd and 3rd CH ON/OFF times.

Note: after pressing 'set?' for the 3rd CH OFF time the display shows 'SET' HW MON-FRI

Setting HW MON - FRI

- 9 Press 'OK' to select the first ON time
- Repeat operations 5 to 8 to set the 1st, 2nd and 3rd HW ON/OFF times.

Note: after pressing 'set?' for the 3rd HW OFF time the display shows 'SET' MON . . . see next page

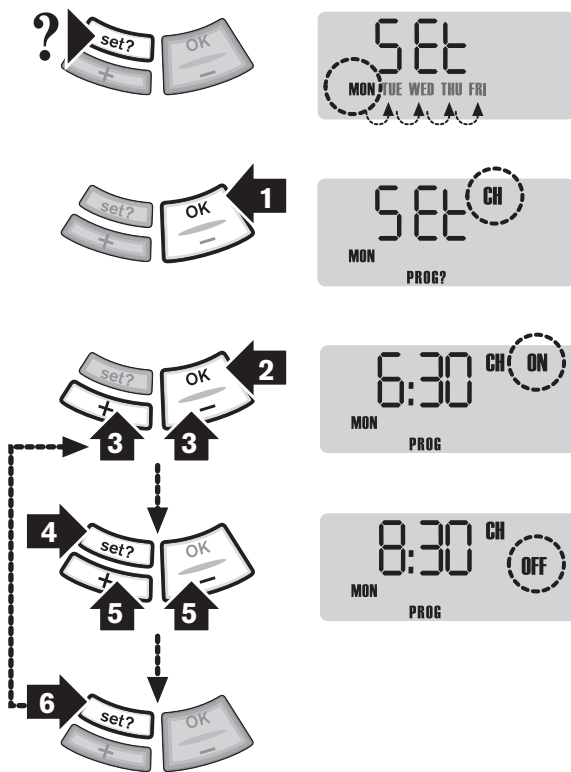

3rd CH OFF



**RECEIVER
SETTING PROGRAMS**

Setting individual weekdays:

Note: if you do not require individual weekday times, then press 'set?' until 'SET' SAT-SUN are displayed and continue on the next page.

► If you do not wish to change the settings for the day displayed, then press 'set?' until the first day you want to change is displayed

Setting CH individual weekdays:

1 Press 'OK' to select weekday

2 Press 'OK' to select CH

Note: speed up the display by holding down the '+' or '-' buttons.

3 Press '+' or '-' to change the ON time

4 Press 'set?' to set the ON time and select the OFF time

5 Press '+' or '-' to change the OFF time

6 Press 'set?' to set the OFF time and select the next ON time

Repeat operations 3 to 6 to set the 2nd and 3rd CH ON/OFF times.

Note: after pressing 'set?' for the 3rd CH OFF time the display shows 'SET' HW for that weekday

Setting HW individual weekdays:

7 Press 'OK' to select the first ON time

Repeat operations 3 to 6 to set the 1st, 2nd and 3rd HW ON/OFF times.

Note: after pressing 'set?' for the 3rd HW OFF time 'SET' and the next weekday are displayed shown . . . after completing the steps above for FRI the display shows 'SET' SAT SUN (see next page)

**USER
INSTRUCTIONS**

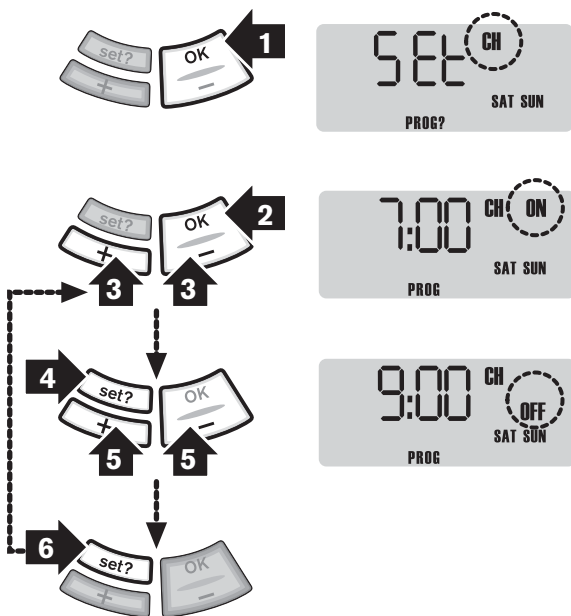

3rd CH OFF



RECEIVER
SETTING PROGRAMS

Setting CH SAT - SUN:

- 1 Press 'OK' to select weekend
- 2 Press 'OK' to select CH
- 3 Press '+' or '-' to change the ON time
- 4 Press 'set?' to set the ON time and select the OFF time
- 5 Press '+' or '-' to change the OFF time
- 6 Press 'set?' to set the OFF time and select the next ON time

Note: speed up the display by holding down the '+' or '-' buttons.

Repeat operations 3 to 6 to set the 2nd and 3rd CH ON/OFF times.

Note: after pressing 'set?' for the 3rd CH OFF time the display shows 'SET' HW for that weekday

Setting HW SAT - SUN:

- 7 Press 'OK' to select the first ON time
- Repeat operations 3 to 6 to set the 1st, 2nd and 3rd HW ON/OFF times.

Note: after pressing 'set?' for the 3rd HW OFF time the display shows 'SET' SAT, see next page.

If you do not require individual weekend times, then press 'SET?' until the normal display is resumed.

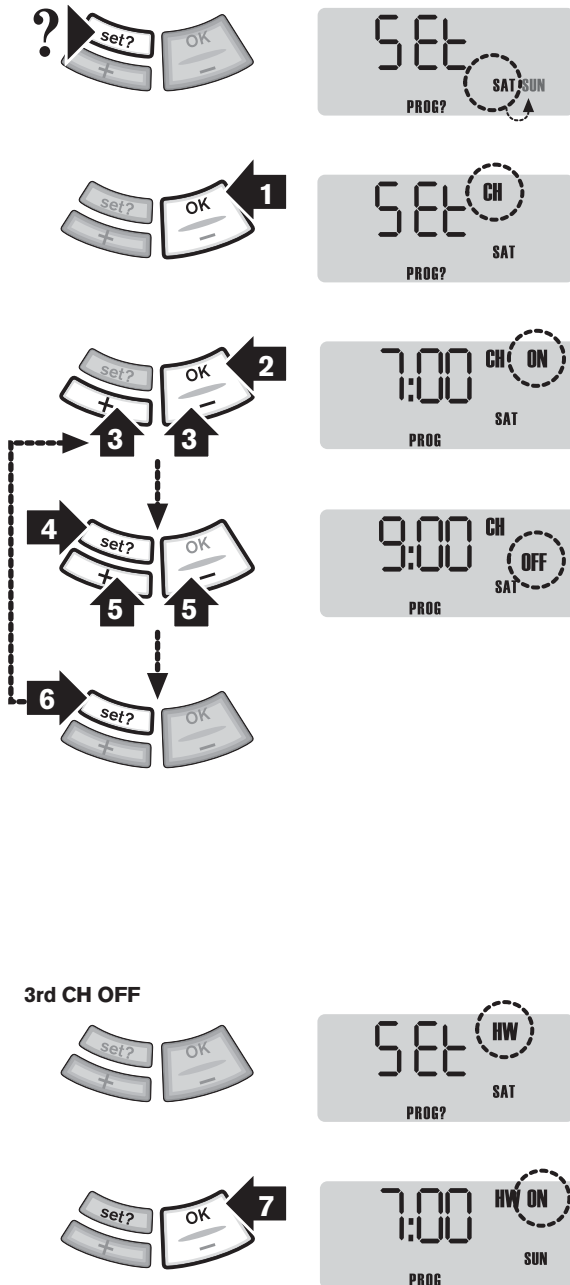

3rd CH OFF

RECEIVER SETTING PROGRAMS

Setting individual weekend days:

Note: if you do not require individual weekend times, then press 'set?' until normal display is shown.

- ▶ If you do not wish to change the settings for 'SAT', then press 'set?' to move to 'SUN'

Setting CH individual weekend days:

1 Press 'OK' to select day displayed

2 Press 'OK' to select CH

Note: speed up the display by holding down the '+' or '-' buttons.

3 Press '+' or '-' to change the ON time

4 Press 'set?' to set the ON time and select the OFF time

5 Press '+' or '-' to change the OFF time

6 Press 'set?' to set the OFF time and select the next ON time

Repeat operations 3 to 6 to set the 2nd and 3rd CH ON/OFF times.

Note: after pressing 'set?' for the 3rd CH OFF time the display shows 'SET' HW for that day

Setting HW individual weekend days:

7 Press 'OK' to select the first ON time

Repeat operations 3 to 6 to set the 1st, 2nd and 3rd HW ON/OFF times.

- ▶ Press 'set?' until the display returns to normal mode.

USER
INSTRUCTIONS

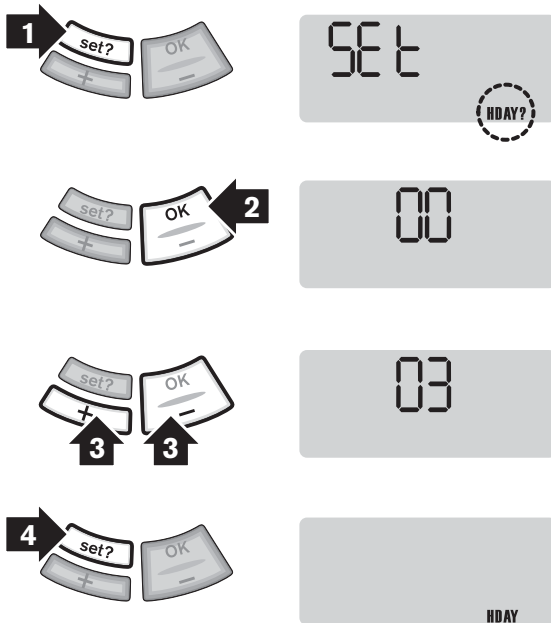

RECEIVER

SETTING HOLIDAYS

- 1 Press the 'set?' button until 'SET' & 'HDAY?' is displayed
- 2 Press 'OK' the display shows 00
- 3 Press '+' & '-' to set the number of days you require the system to be off
- 4 Press 'set?' then 'HDAY' is shown in the display and no demand for heating will be made from the programmer.

The program will return to normal after the set number of days.

- ▶ To cancel the holiday setting and return to normal operation, press any button.

Note: the programmer counts each pass through midnight as a day.

For example, if you don't want the heating on from Saturday morning until Tuesday morning, set for 3 days.



RECEIVER

SETTING THE CLOCK

- 1 Press the 'set?' button until 'SET' & 'CLOCK?' are shown in the display
- 2 Press 'OK' displays '24hr' & 'ON'
- 3 Press '+' to toggle between 24hr and 12hr display
- 4 Press 'set?' to set the clock and the hours flash on the display
- 5 Press '+' to correct hour

Note: speed up the display by holding down the '+' or '-' buttons.

- 6 Press the 'set?' button to set the correct hour
- 7 Press '+' or '-' to correct minutes
- 8 Press the 'set?' button to set the correct minutes. 'SET' & 'DATE?' appears in the display.

Note: if the day displayed is incorrect the date needs resetting. To change the date see 'SETTING THE DATE'.

If you do not wish to change the date, press 'set?' to return to normal display.

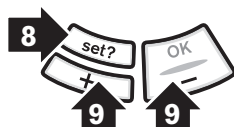
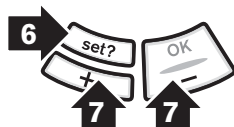
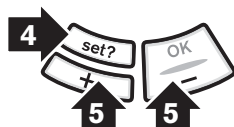

RECEIVER

SETTING THE DATE

Note: if the day displayed is incorrect the date needs resetting as follows:

- 1 Press the 'set?' button until 'SET' & 'DATE?' are shown in the display
- 2 Press the 'OK' button once, the year flashes on the display
- 3 Press '+' or '-' to correct year
- 4 Press the 'set?' button and the month flashes on the display
- 5 Press '+' or '-' to correct month
- 6 Press the 'set?' button and the day flashes on the display
- 7 Press '+' or '-' to correct day
- 8 Press the 'set?' button to set the DLS and the 'ON' flashes
- 9 Press '+' or '-' for 'ON' or 'OFF'
- 10 Press 'set?' twice to return to normal display.

BATTERY REPLACEMENT

Battery symbol:

A flashing battery symbol shown in the display of transmitter (A) indicates that the batteries need replacing within 30 days.

Note: Once the batteries are removed you have 1 minute to replace the batteries before your program settings are lost.

Replacing the batteries:

Do not use rechargeable batteries

- 1 Slide open battery compartment (B)
- 2 ▶ Remove existing batteries (C) and dispose of safely
 - ▶ Replace batteries with the same type and check they are correctly fitted into the battery compartment (C)
- 3 Replace the right hand battery compartment (B) first followed by the left hand battery compartment

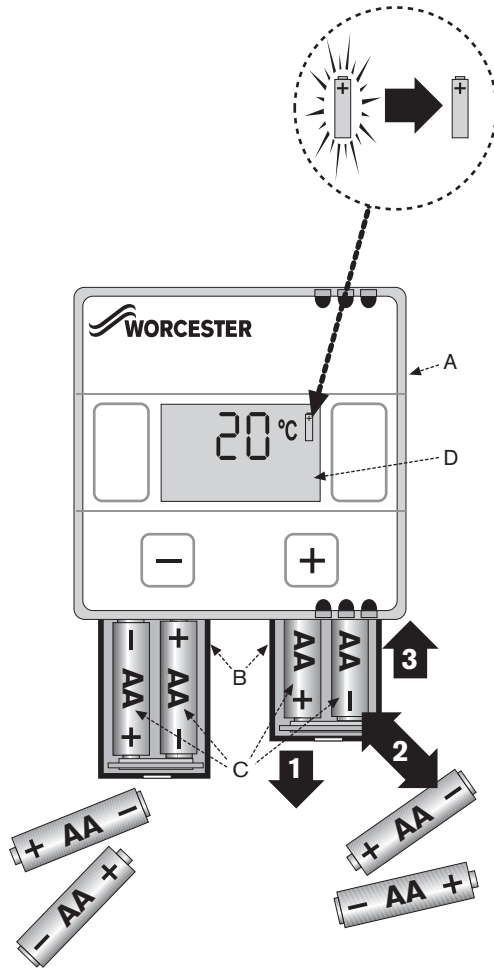

USER
INSTRUCTIONS

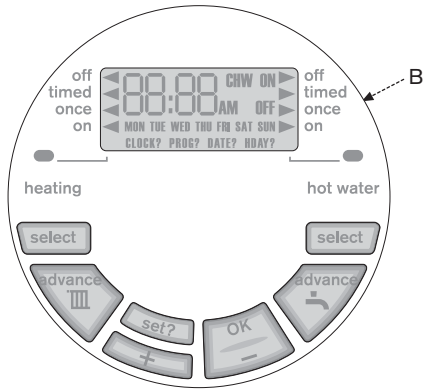
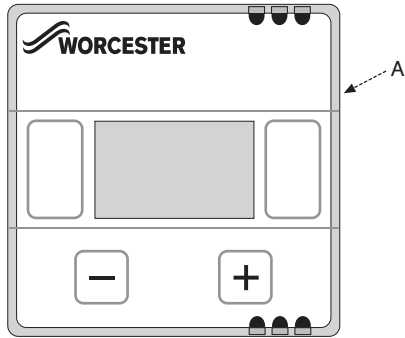

MAINTENANCE & SPARES

Maintenance:

- ▶ The transmitter (A) and receiver (B) require no maintenance
- ▶ The outer casing can be wiped clean using a dry cloth, do not use polish or detergents

Servicing:

- ▶ These units cannot be serviced.
- ▶ Should the existing unit fail to function correctly, check:
 - ▶ receiver times and program settings are correct
 - ▶ the RF signal link is setup
 - ▶ transmitter batteries are the correct type and are correctly fitted.

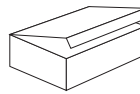

Replacement Parts:

- ▶ Transmitter (Roomstat) replacement part number: 8-716-106-670-0
- ▶ Receiver (DT20RF): replacement part number: 8-716-106-669-0