



BOSCH

Compress 5800i hybrid schematics

System schematic and wiring diagrams

4kW to 7kW.





Compress 5800i 4-7kW

Hybrid systems Option 1

CSH5800iAW Option 1 with combi boiler and Easy control with eTRVs

CSH5800iAW Option 1 with combi boiler , 2z and Easy control

CSH5800iAW Option 1 with combi boiler,1 heating circuit and Easy control

CSH5800iAW Option 1 with combi boiler , 1 heating circuit and third party control

CSH5800iAW Option 1 with combi boiler , 2z and third party control

Option 2

CSH5800iAW Option 2 with combi boiler,2z and Easy control

CSH5800iAW Option 2 with combi boiler,1 heating circuit and Easy control

CSH5800iAW Option 2 with combi boiler and Easy control with eTRVs

CSH5800iAW Option 2 with combi boiler , 1 heating circuit and third party control

CSH5800iAW Option 2 with combi boiler , 2z using CH120 and 230 V control

System

Wiring



Key	Description
	T1 and T0 sensors
	Isolation valve
	Drain off valve
	Magnetic filter
	Bypass
	Low loss header
	Pressure relief valve (PRV)
	eTRV

*At least one heating circuit should remain fully open
 *Hydraulic separation with a secondary pump may be required if the hydraulic resistance of the central heating system exceeds 250 mbar at a 10 K delta T

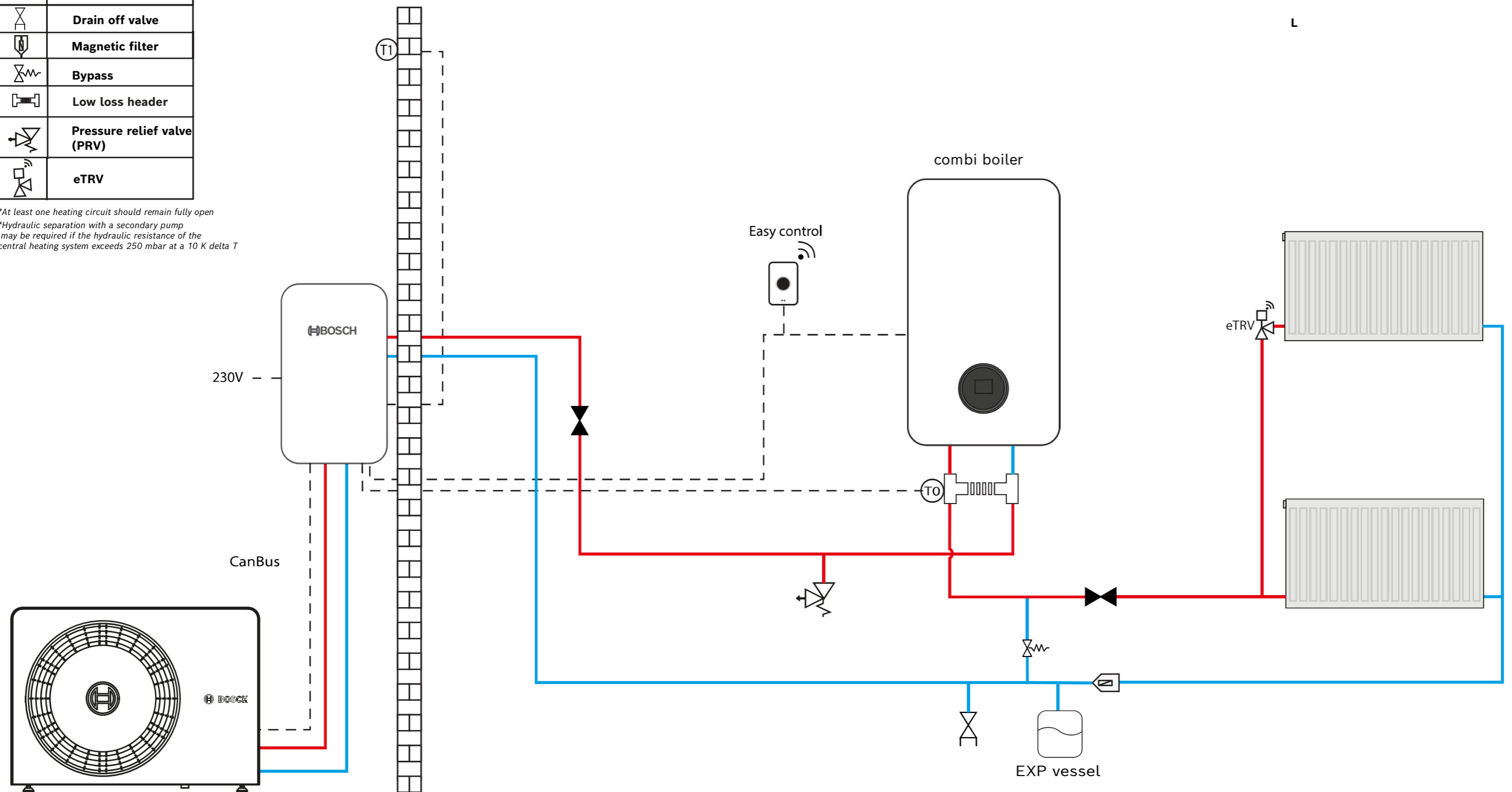

All electrical work should be carried out by a registered engineer. Wiring must comply with the latest IET wiring regulations. Isolate the mains electricity supply before starting any work and observe all relevant safety precautions. Refer to all relevant product installation manuals for safety and installation instructions. Whilst it is always our intention to fully assist, it is essential to recognise that all information given by the company is provided in good faith and based upon the information available. Connection labels may not match those of the products installed on site. We recommend that advice should always be checked with your installer, electrician or the manufacturer of the product in question. Consequently, the company cannot be held responsible for any liability relating to the use or repetition of such information or part thereof. In addition, whilst making every reasonable effort to monitor the performance and quality of our supply, installation and service network, we do not accept responsibility for the workmanship or operation of any third party company.





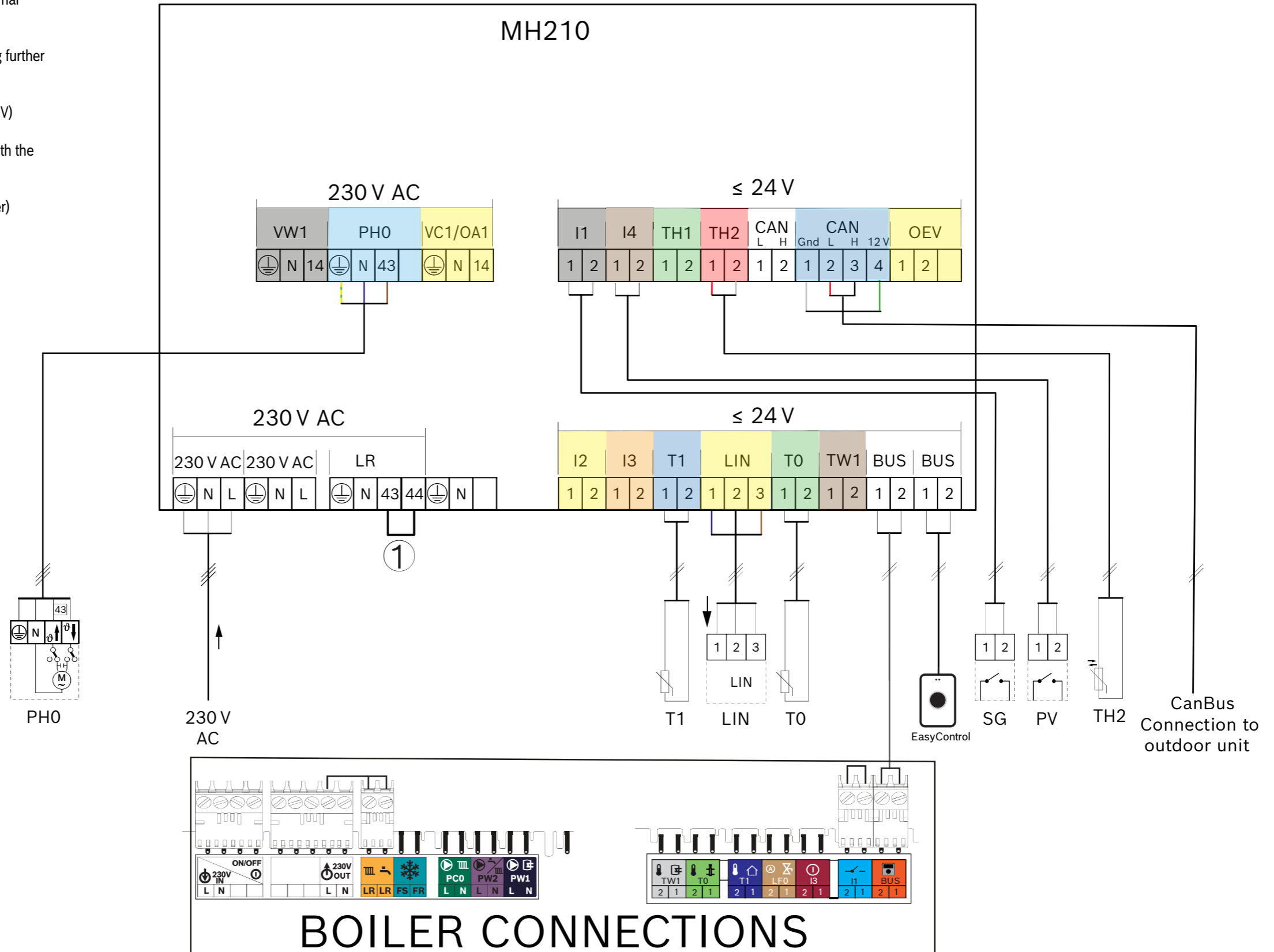



- [1] This jumper must be removed when connecting an external 230 V controller.
- 230 V AC Mains voltage connection, incoming
- 230 V AC Mains voltage connection, outgoing, for supplying further modules
- PH0-CH pump in hybrid box
- LR 43/44 Connection 230 V external room thermostat (230 V)
- Boiler BUS EMS BUS to boiler
- CAN CAN Power, CAN Data (connection/communication with the heat pump outdoor unit); the additional two-pole CAN connection on the left is intended for software updates
- EasyControl BUS Control unit for hybrid systems (controller)
- I1 SG Ready 1
- I4 SG Ready 2
- LIN Pump with LIN-BUS communication
- Terminal assignment:
- 1-blue, grey
- 2-black
- 3-brown
- PV Photovoltaic system (If applicable)
- SG Smart grid (If applicable)
- T0 Low loss header temperature sensor
- T1 Outside temperature sensor
- TH2 Temperature sensor return to heat pump

Hybrid manager



All electrical work should be carried out by a registered engineer. Wiring must comply with the latest IET wiring regulations. Isolate the mains electricity supply before starting any work and observe all relevant safety precautions. Refer to all relevant product installation manuals for safety and installation instructions. Whilst it is always our intention to fully assist, it is essential to recognise that all information given by the company is provided in good faith and based upon the information available. Connection labels may not match those of the products installed on site. We recommend that advice should always be checked with your installer, electrician or the manufacturer of the product in question. Consequently, the company cannot be held responsible for any liability relating to the use or repetition of such information or part thereof. In addition, whilst making every reasonable effort to monitor the performance and quality of our supply, installation and service network, we do not accept responsibility for the workmanship or operation of any third party company.



Key	Description
	T1 and T0 sensors
	Isolation valve
	Drain off valve
	Magnetic filter
	Bypass
	Low loss header
	Pressure relief valve (PRV)
	Two port valve

*At least one heating circuit should remain fully open
 *Hydraulic separation with a secondary pump may be required if the hydraulic resistance of the central heating system exceeds 250 mbar at a 10 K delta T

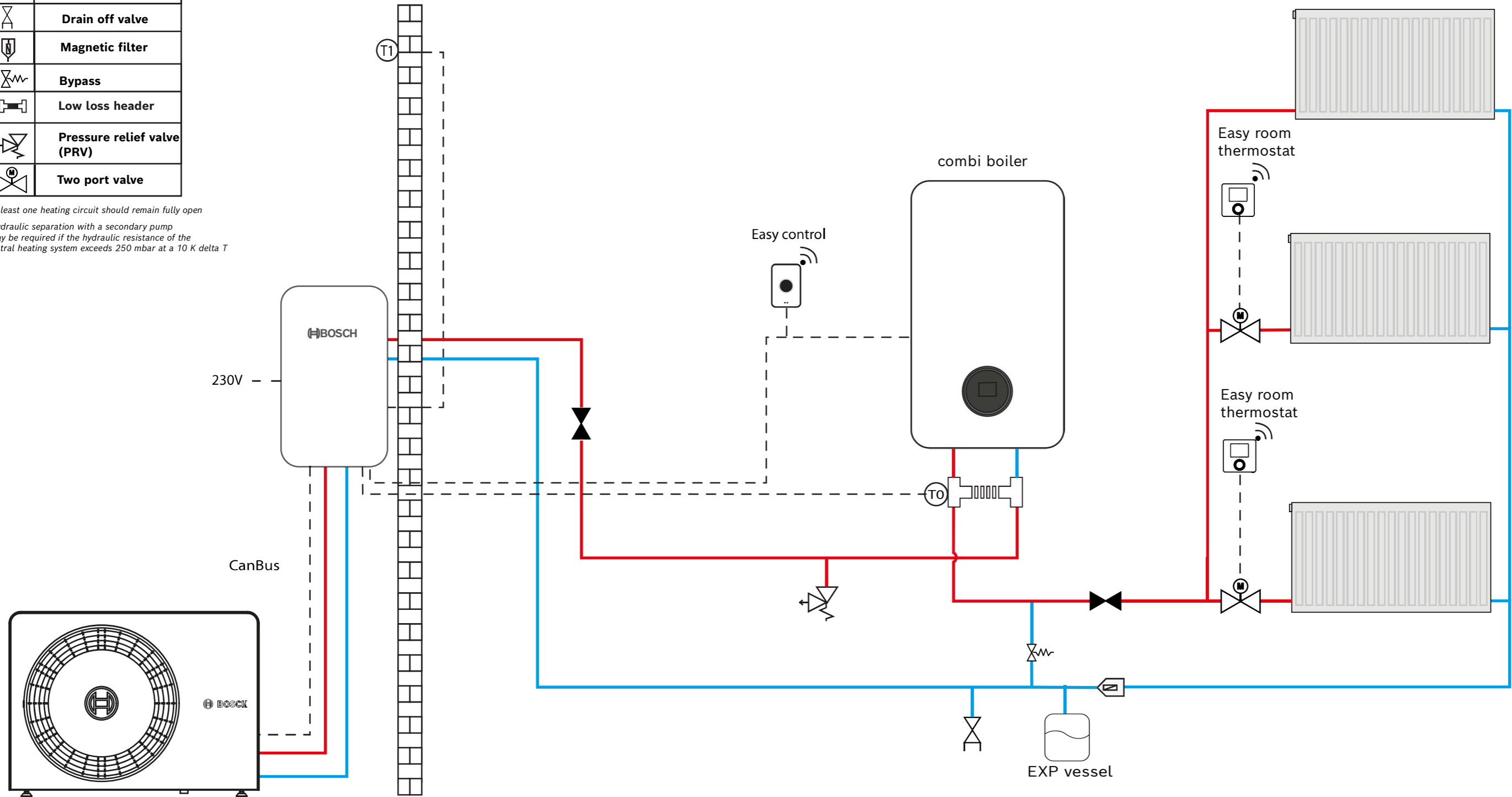

All electrical work should be carried out by a registered engineer. Wiring must comply with the latest IET wiring regulations.

Isolate the mains electricity supply before starting any work and observe all relevant safety precautions. Refer to all relevant product installation manuals for safety and installation instructions.

Whilst it is always our intention to fully assist, it is essential to recognise that all information given by the company is provided in good faith and based upon the information available. Connection labels may not match those of the products installed on site. We recommend that advice should always be checked with your installer, electrician or the manufacturer of the product in question. Consequently, the company cannot be held responsible for any liability relating to the use or repetition of such information or part thereof. In addition, whilst making every reasonable effort to monitor the performance and quality of our supply, installation and service network, we do not accept responsibility for the workmanship or operation of any third party company.

For further information or assistance please contact:
 Email: system.design@uk.bosch.com Tel: 01905751464

- [1] This jumper must be removed when connecting an external 230 V controller.
- 230 V AC Mains voltage connection, incoming
- 230 V AC Mains voltage connection, outgoing, for supplying further modules
- PH0-CH pump in hybrid box
- LR 43/44 Connection 230 V external room thermostat (230 V)
- Boiler BUS EMS BUS to boiler
- CAN CAN Power, CAN Data (connection/communication with the heat pump outdoor unit); the additional two-pole CAN connection on the left is intended for software updates
- EasyControl BUS Control unit for hybrid systems (controller)
- I1 SG Ready 1
- I4 SG Ready 2
- LIN Pump with LIN-BUS communication
- Terminal assignment:
- 1-blue, grey
- 2-black
- 3-brown
- PV Photovoltaic system (If applicable)
- SG Smart grid (If applicable)
- T0 Low loss header temperature sensor
- T1 Outside temperature sensor
- TH2 Temperature sensor return to heat pump

Hybrid manager

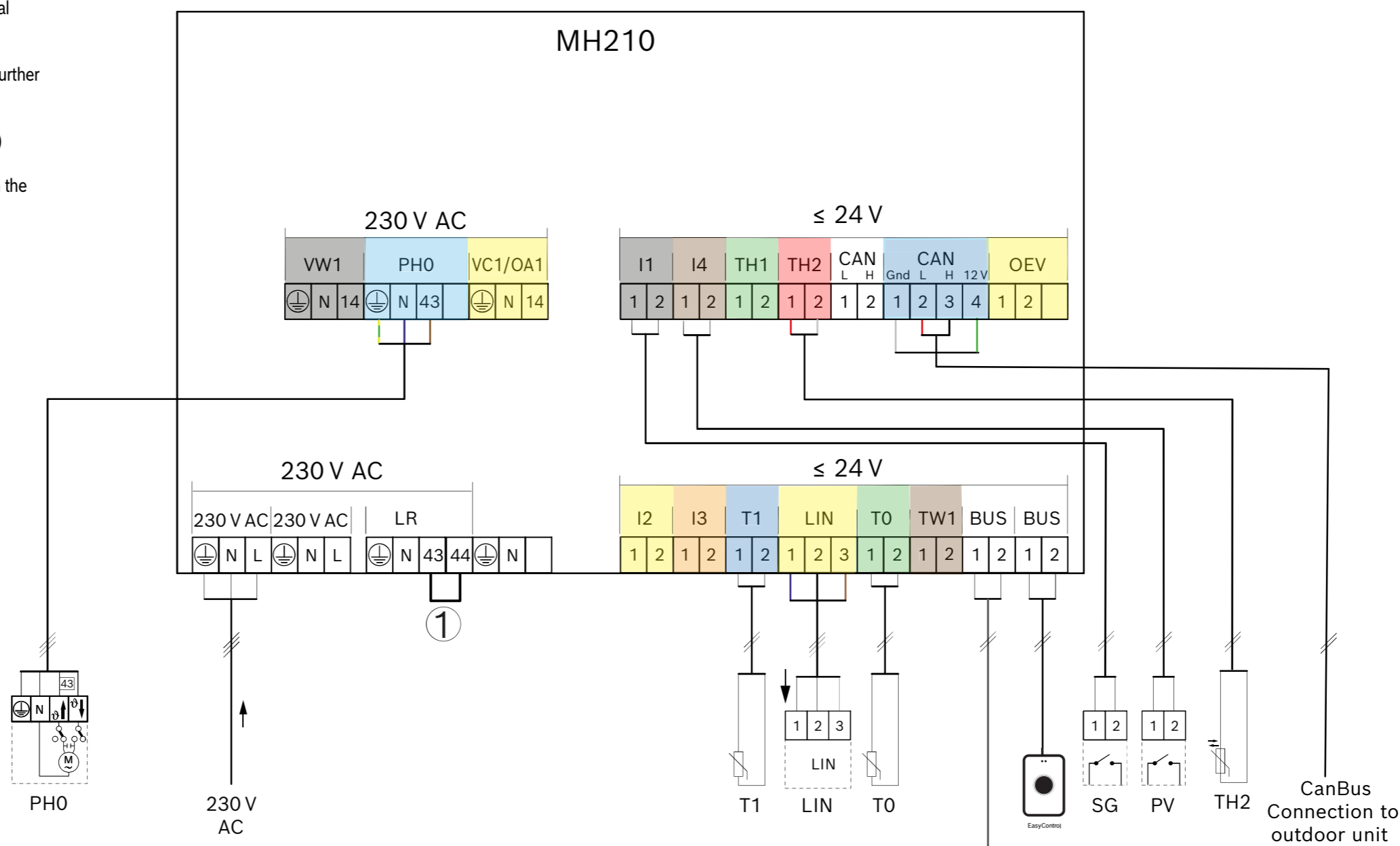

Thermostat connections

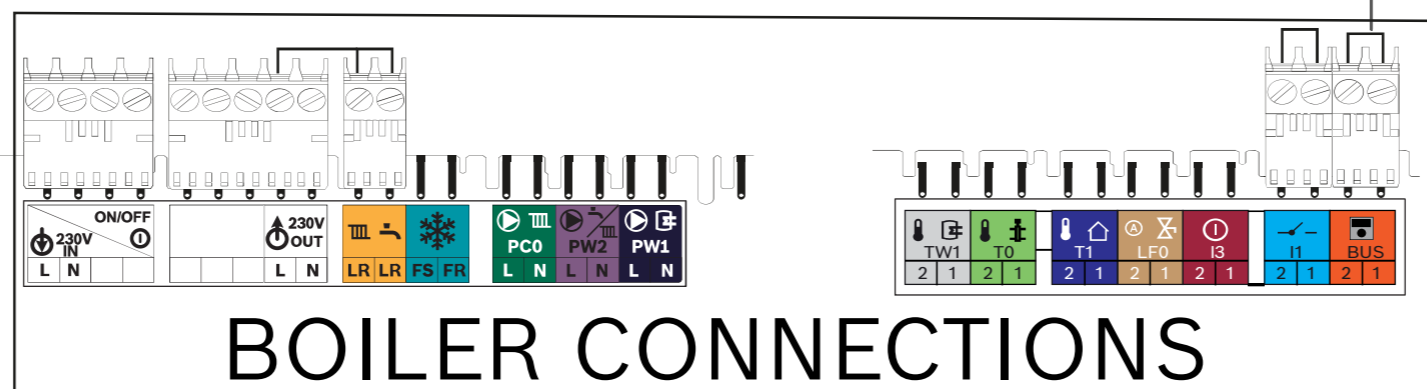
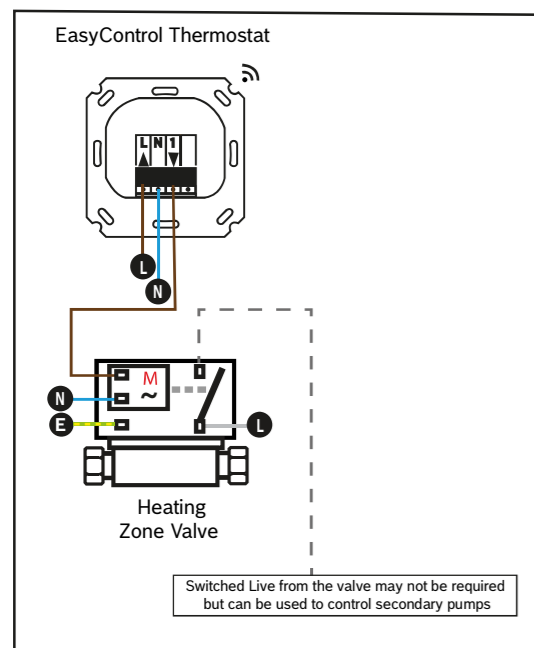







All electrical work should be carried out by a registered engineer. Wiring must comply with the latest IET wiring regulations.

Isolate the mains electricity supply before starting any work and observe all relevant safety precautions. Refer to all relevant product installation manuals for safety and installation instructions.

Whilst it is always our intention to fully assist, it is essential to recognise that all information given by the company is provided in good faith and based upon the information available. Connection labels may not match those of the products installed on site. We recommend that advice should always be checked with your installer, electrician or the manufacturer of the product in question. Consequently, the company cannot be held responsible for any liability relating to the use or repetition of such information or part thereof. In addition, whilst making every reasonable effort to monitor the performance and quality of our supply, installation and service network, we do not accept responsibility for the workmanship or operation of any third party company.



Key	Description
	T1 and T0 sensors
	Isolation valve
	Drain off valve
	Magnetic filter
	Bypass
	Low loss header
	Pressure relief valve (PRV)

*At least one heating circuit should remain fully open
 *Hydraulic separation with a secondary pump may be required if the hydraulic resistance of the central heating system exceeds 250 mbar at a 10 K delta T

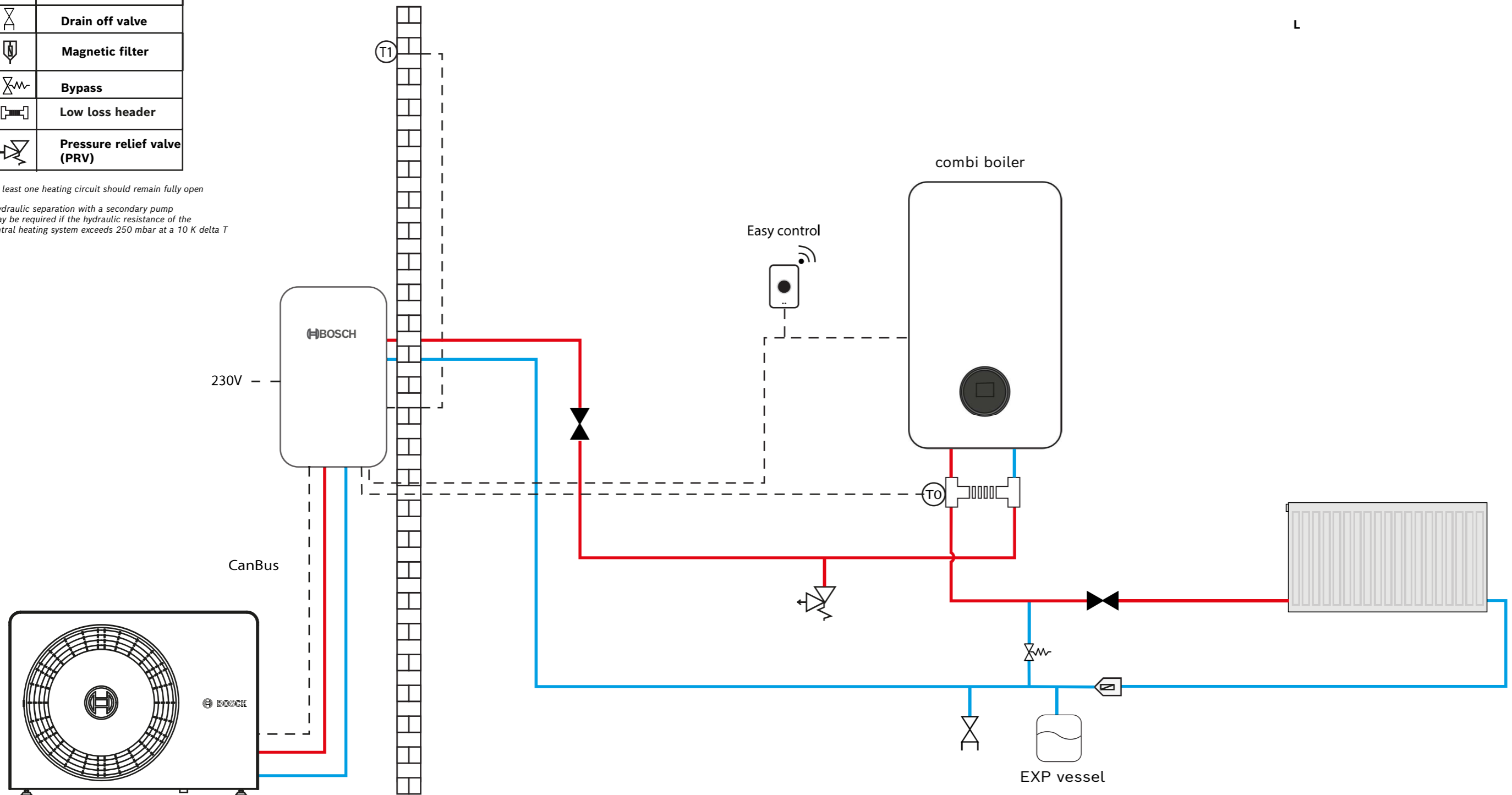

All electrical work should be carried out by a registered engineer. Wiring must comply with the latest IET wiring regulations.

Isolate the mains electricity supply before starting any work and observe all relevant safety precautions. Refer to all relevant product installation manuals for safety and installation instructions.







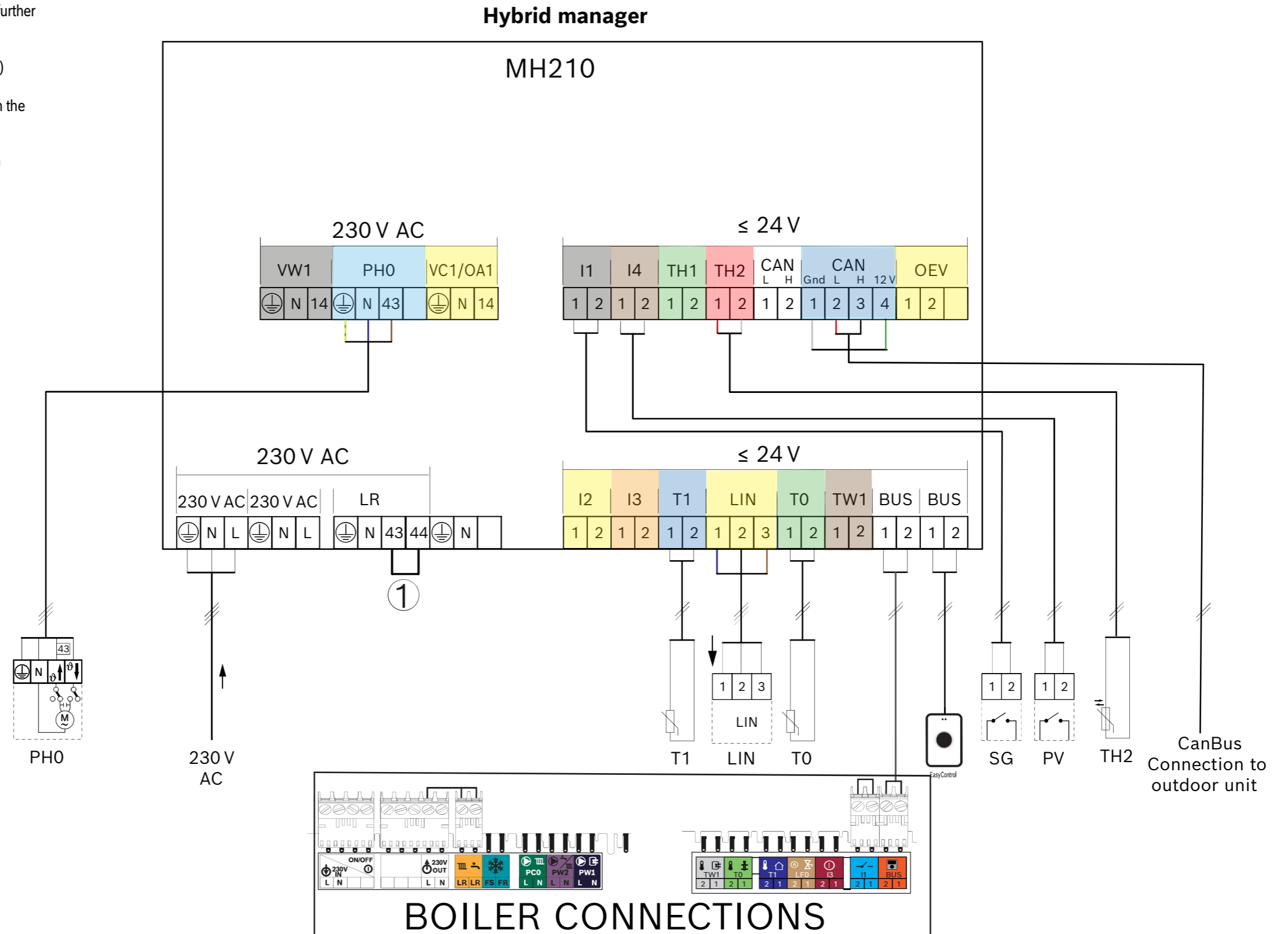

Whilst it is always our intention to fully assist, it is essential to recognise that all information given by the company is provided in good faith and based upon the information available. Connection labels may not match those of the products installed on site. We recommend that advice should always be checked with your installer, electrician or the manufacturer of the product in question. Consequently, the company cannot be held responsible for any liability relating to the use or repetition of such information or part thereof. In addition, whilst making every reasonable effort to monitor the performance and quality of our supply, installation and service network, we do not accept responsibility for the workmanship or operation of any third party company.

For further information or assistance please contact:
 Email: system.design@uk.bosch.com Tel: 01905751464

- [1] This jumper must be removed when connecting an external 230 V controller.
- 230 V AC Mains voltage connection, incoming
- 230 V AC Mains voltage connection, outgoing, for supplying further modules
- PH0-CH pump in hybrid box
- LR 43/44 Connection 230 V external room thermostat (230 V)
- Boiler BUS EMS BUS to boiler
- CAN CAN Power, CAN Data (connection/communication with the heat pump outdoor unit); the additional two-pole CAN connection on the left is intended for software updates
- EasyControl BUS Control unit for hybrid systems (controller)
- I1 SG Ready 1
- I4 SG Ready 2
- LIN Pump with LIN-BUS communication
- Terminal assignment:
- 1-blue, grey
- 2-black
- 3-brown
- PV Photovoltaic system (If applicable)
- SG Smart grid (If applicable)
- T0 Low loss header temperature sensor
- T1 Outside temperature sensor
- TH2 Temperature sensor return to heat pump



All electrical work should be carried out by a registered engineer. Wiring must comply with the latest IET wiring regulations. Isolate the mains electricity supply before starting any work and observe all relevant safety precautions. Refer to all relevant product installation manuals for safety and installation instructions. Whilst it is always our intention to fully assist, it is essential to recognise that all information given by the company is provided in good faith and based upon the information available. Connection labels may not match those of the products installed on site. We recommend that advice should always be checked with your installer, electrician or the manufacturer of the product in question. Consequently, the company cannot be held responsible for any liability relating to the use or repetition of such information or part thereof. In addition, whilst making every reasonable effort to monitor the performance and quality of our supply, installation and service network, we do not accept responsibility for the workmanship or operation of any third party company.

Key	Description
	T1 and T0 sensors
	Isolation valve
	Drain off valve
	Bypass
	Magnetic filter
	Low loss header
	Pressure relief valve (PRV)
	230 V controls
	Blending valve

*At least one heating circuit should remain fully open
 *Hydraulic separation with a secondary pump may be required if the hydraulic resistance of the central heating system exceeds 250 mbar at a 10 K delta T

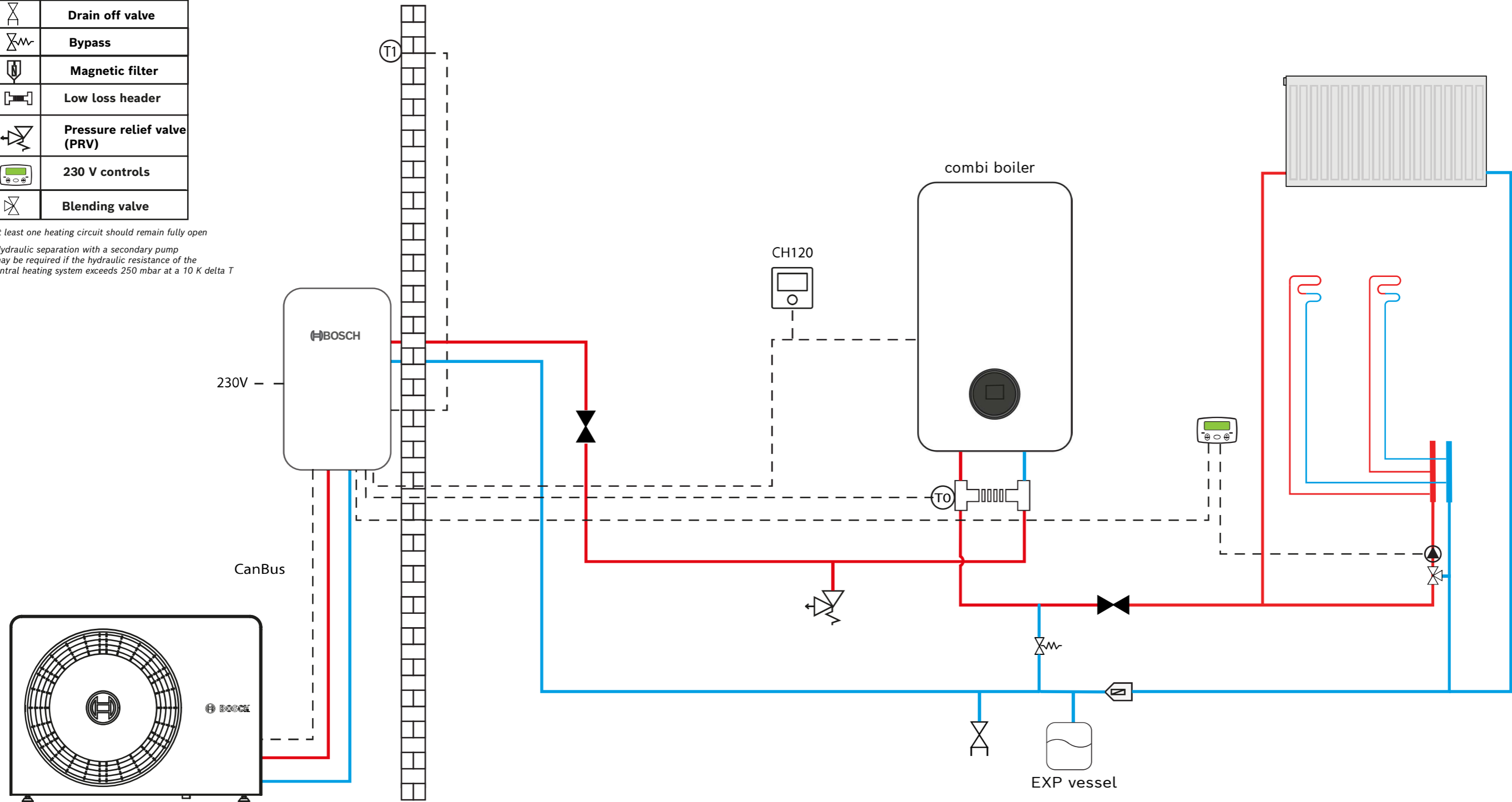

All electrical work should be carried out by a registered engineer. Wiring must comply with the latest IET wiring regulations.
 Isolate the mains electricity supply before starting any work and observe all relevant safety precautions. Refer to all relevant product installation manuals for safety and installation instructions.
 Whilst it is always our intention to fully assist, it is essential to recognise that all information given by the company is provided in good faith and based upon the information available. Connection labels may not match those of the products installed on site. We recommend that advice should always be checked with your installer, electrician or the manufacturer of the product in question. Consequently, the company cannot be held responsible for any liability relating to the use or repetition of such information or part thereof. In addition, whilst making every reasonable effort to monitor the performance and quality of our supply, installation and service network, we do not accept responsibility for the workmanship or operation of any third party company.

For further information or assistance please contact:
 Email: system.design@uk.bosch.com Tel: 01905751464

Hybrid manager

- [1] This jumper must be removed when connecting an external 230 V controller.
- 230 V AC Mains voltage connection, incoming
- 230 V AC Mains voltage connection, outgoing, for supplying further modules
- PH0-CH pump in hybrid box
- LR 43/44 Connection 230 V external room thermostat (230 V)
- Boiler BUS EMS BUS to boiler
- CAN CAN Power, CAN Data (connection/communication with the heat pump outdoor unit); the additional two-pole CAN connection on the left is intended for software updates
- CON BUS Control unit for hybrid systems (controller)
- I1 SG Ready 1
- I4 SG Ready 2
- LIN Pump with LIN-BUS communication
- Terminal assignment:
- 1-blue, grey
- 2-black
- 3-brown
- PV Photovoltaic system (If applicable)
- SG Smart grid (If applicable)
- T0 Low loss header temperature sensor
- T1 Outside temperature sensor
- TH2 Temperature sensor return to heat pump

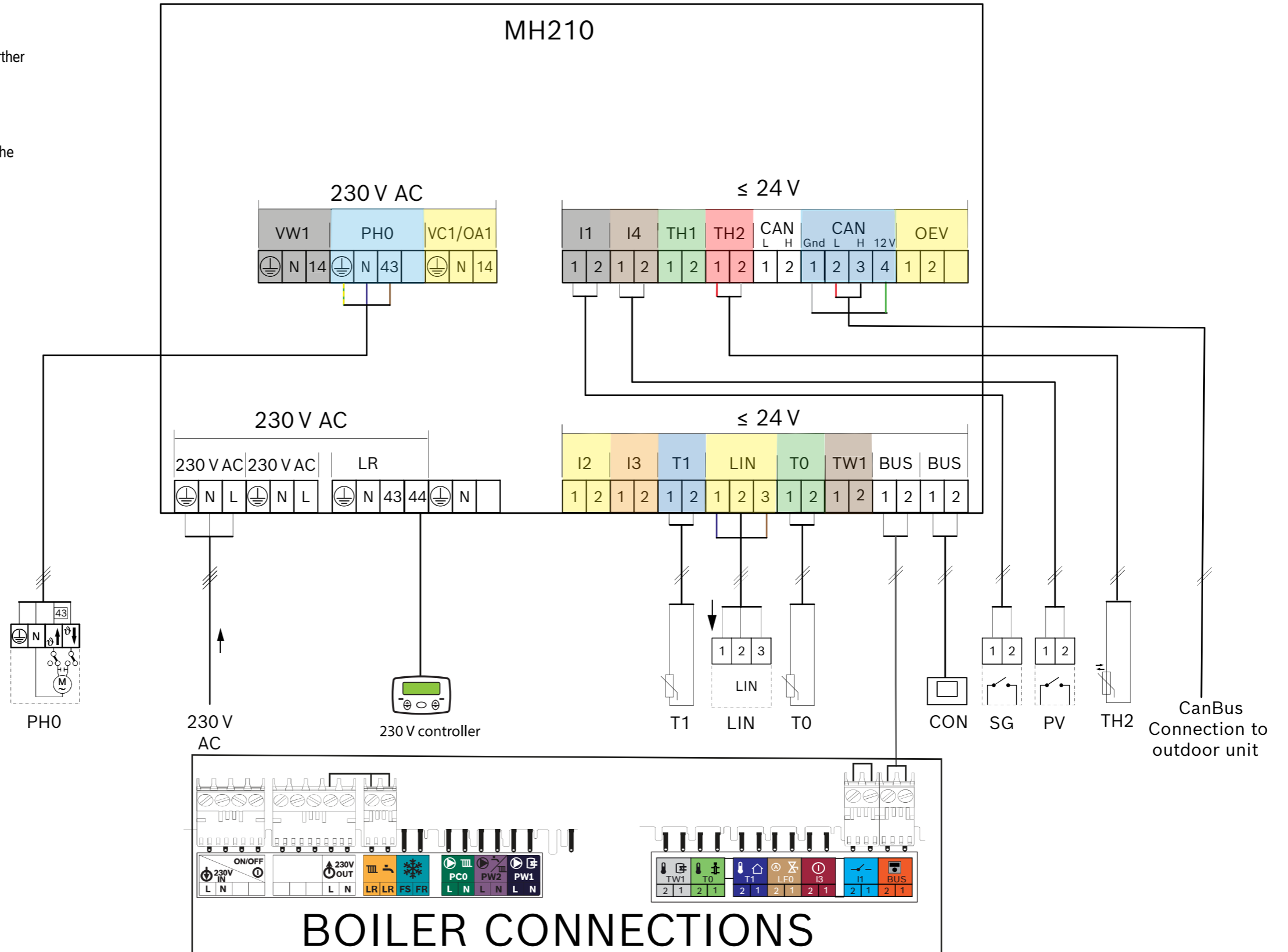









All electrical work should be carried out by a registered engineer. Wiring must comply with the latest IET wiring regulations.

Isolate the mains electricity supply before starting any work and observe all relevant safety precautions. Refer to all relevant product installation manuals for safety and installation instructions.

Whilst it is always our intention to fully assist, it is essential to recognise that all information given by the company is provided in good faith and based upon the information available. Connection labels may not match those of the products installed on site. We recommend that advice should always be checked with your installer, electrician or the manufacturer of the product in question. Consequently, the company cannot be held responsible for any liability relating to the use or repetition of such information or part thereof. In addition, whilst making every reasonable effort to monitor the performance and quality of our supply, installation and service network, we do not accept responsibility for the workmanship or operation of any third party company.

For further information or assistance please contact:
 Email: system.design@uk.bosch.com Tel: 01905751464



Key	Description
	T1 and T0 sensors
	Isolation valve
	Drain off valve
	Bypass
	Magnetic filter
	Low loss header
	Pressure relief valve (PRV)
	230 V controls
	Two port valve

*At least one heating circuit should remain fully open

*Hydraulic separation with a secondary pump may be required if the hydraulic resistance of the central heating system exceeds 250 mbar at a 10 K delta T

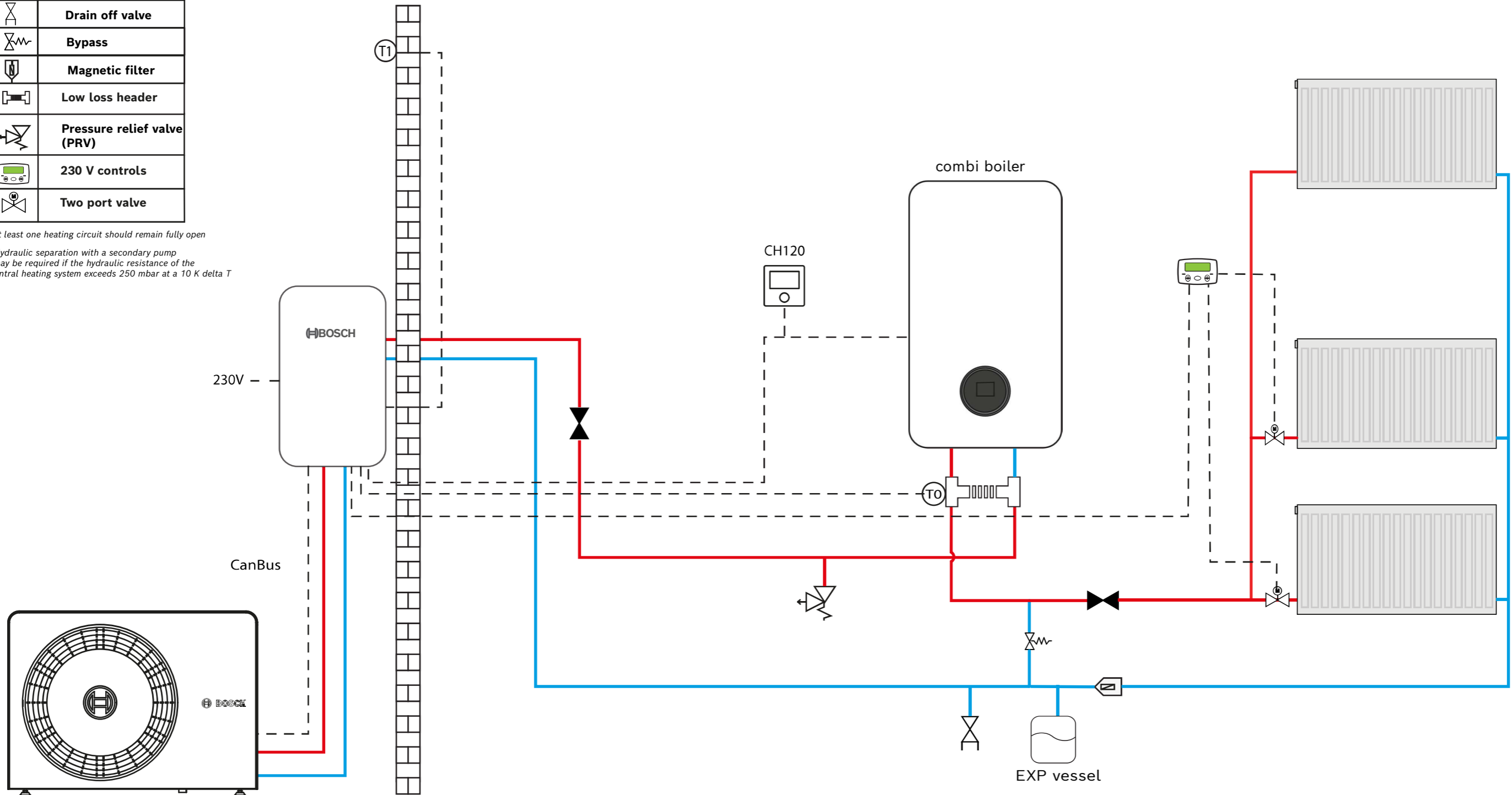

All electrical work should be carried out by a registered engineer. Wiring must comply with the latest IET wiring regulations.

Isolate the mains electricity supply before starting any work and observe all relevant safety precautions. Refer to all relevant product installation manuals for safety and installation instructions.

Whilst it is always our intention to fully assist, it is essential to recognise that all information given by the company is provided in good faith and based upon the information available. Connection labels may not match those of the products installed on site. We recommend that advice should always be checked with your installer, electrician or the manufacturer of the product in question. Consequently, the company cannot be held responsible for any liability relating to the use or repetition of such information or part thereof. In addition, whilst making every reasonable effort to monitor the performance and quality of our supply, installation and service network, we do not accept responsibility for the workmanship or operation of any third party company.

For further information or assistance please contact:
Email: system.design@uk.bosch.com Tel: 01905751464

Hybrid manager

- [1] This jumper must be removed when connecting an external 230 V controller.
- 230 V AC Mains voltage connection, incoming
- 230 V AC Mains voltage connection, outgoing, for supplying further modules
- PH0-CH pump in hybrid box
- LR 43/44 Connection 230 V external room thermostat (230 V)
- Boiler BUS EMS BUS to boiler
- CAN CAN Power, CAN Data (connection/communication with the heat pump outdoor unit); the additional two-pole CAN connection on the left is intended for software updates
- CON BUS Control unit for hybrid systems (controller)
- I1 SG Ready 1
- I4 SG Ready 2
- LIN Pump with LIN-BUS communication
- Terminal assignment:
- 1-blue, grey
- 2-black
- 3-brown
- PV Photovoltaic system (If applicable)
- SG Smart grid (If applicable)
- T0 Low loss header temperature sensor
- T1 Outside temperature sensor
- TH2 Temperature sensor return to heat pump

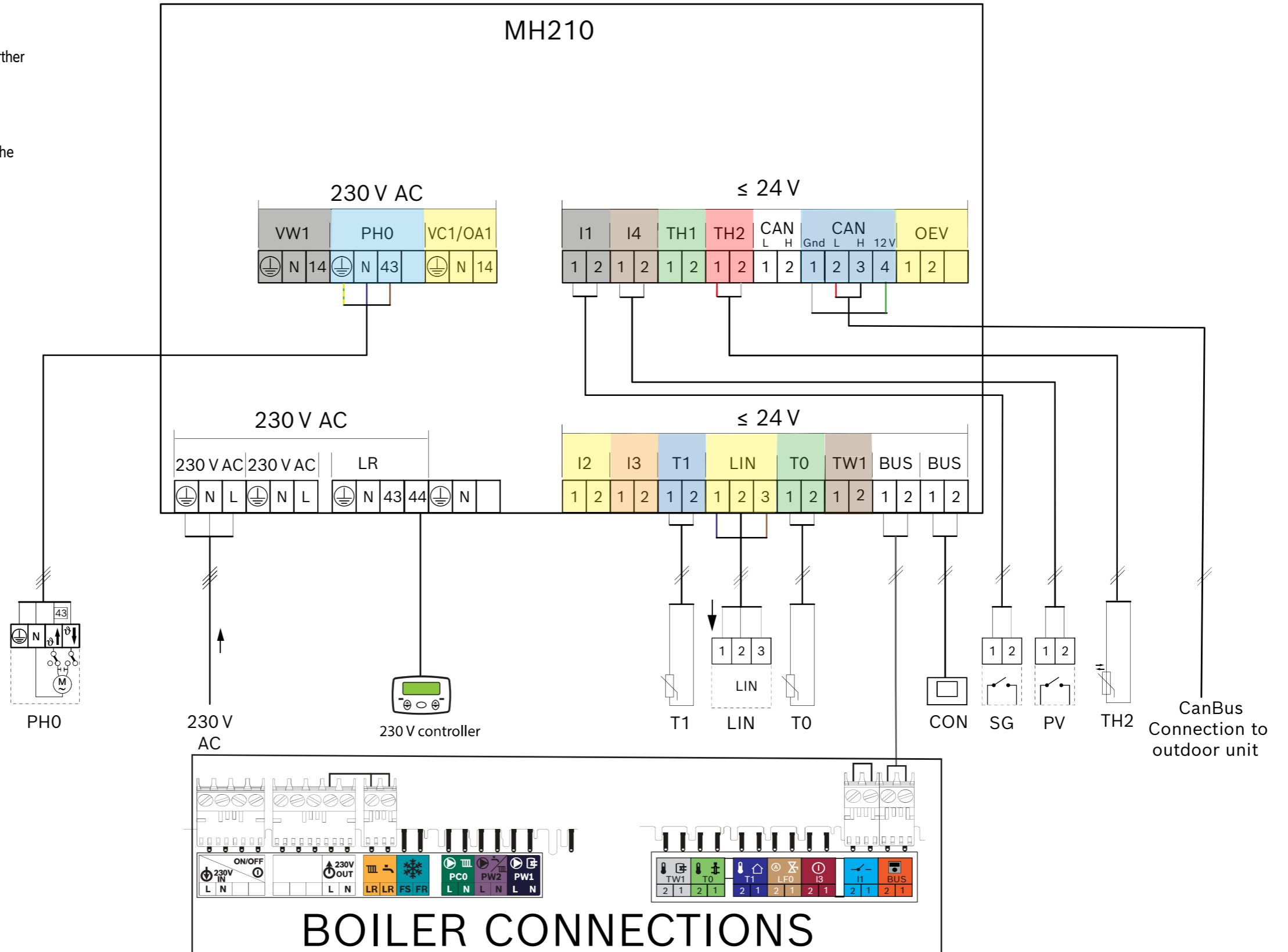

All electrical work should be carried out by a registered engineer. Wiring must comply with the latest IET wiring regulations. Isolate the mains electricity supply before starting any work and observe all relevant safety precautions. Refer to all relevant product installation manuals for safety and installation instructions. Whilst it is always our intention to fully assist, it is essential to recognise that all information given by the company is provided in good faith and based upon the information available. Connection labels may not match those of the products installed on site. We recommend that advice should always be checked with your installer, electrician or the manufacturer of the product in question. Consequently, the company cannot be held responsible for any liability relating to the use or repetition of such information or part thereof. In addition, whilst making every reasonable effort to monitor the performance and quality of our supply, installation and service network, we do not accept responsibility for the workmanship or operation of any third party company.

Key	Description
	T1 and T0 sensors
	Isolation valve
	Drain off valve
	Magnetic filter
	Bypass
	Low loss header
	Pressure relief valve (PRV)
	Two port valve

*At least one heating circuit should remain fully open

*Hydraulic separation with a secondary pump may be required if the hydraulic resistance of the central heating system exceeds 250 mbar at a 10 K delta T

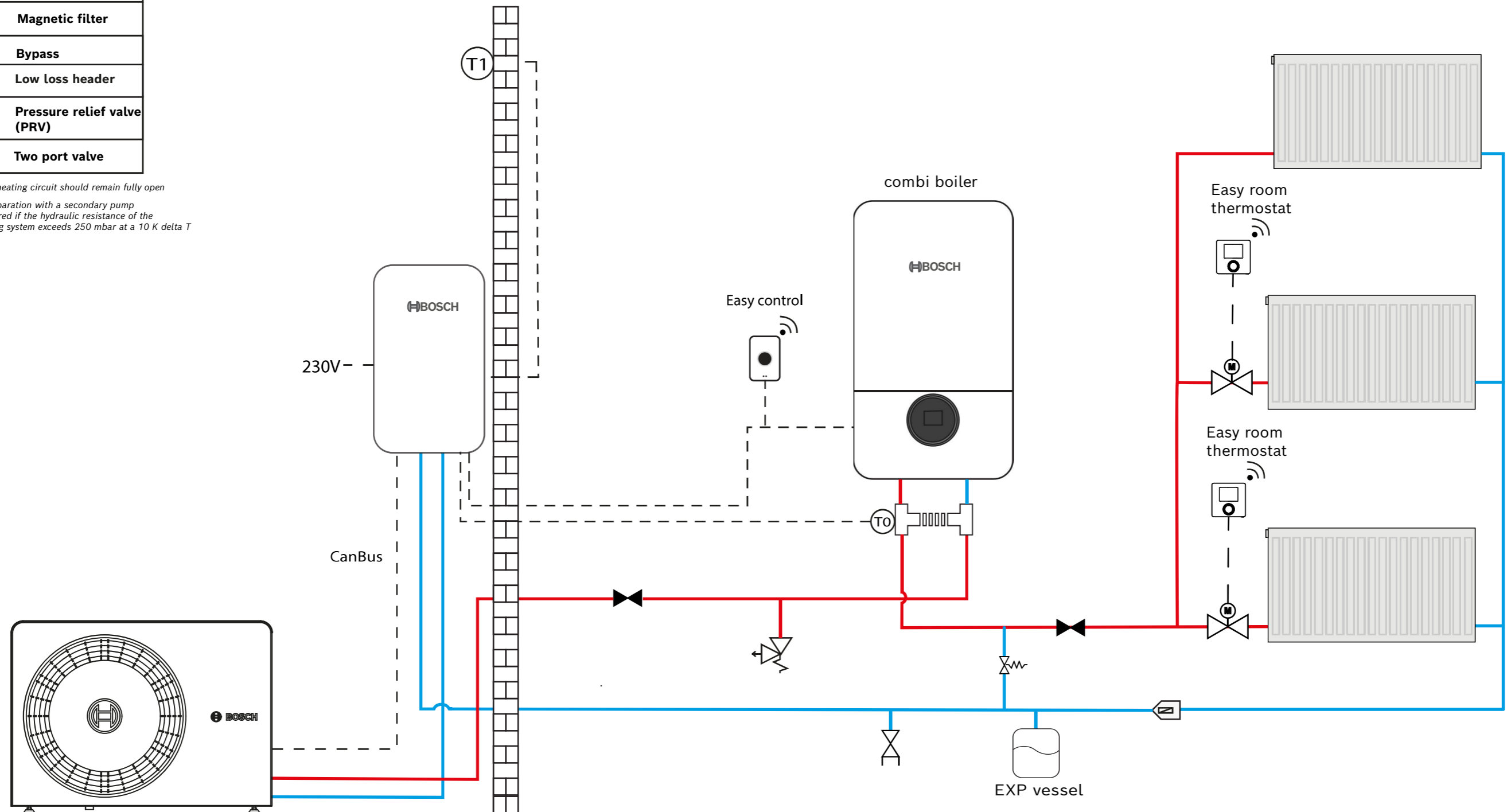

All electrical work should be carried out by a registered engineer. Wiring must comply with the latest IET wiring regulations.

Isolate the mains electricity supply before starting any work and observe all relevant safety precautions. Refer to all relevant product installation manuals for safety and installation instructions.

Whilst it is always our intention to fully assist, it is essential to recognise that all information given by the company is provided in good faith and based upon the information available. Connection labels may not match those of the products installed on site. We recommend that advice should always be checked with your installer, electrician or the manufacturer of the product in question. Consequently, the company cannot be held responsible for any liability relating to the use or repetition of such information or part thereof. In addition, whilst making every reasonable effort to monitor the performance and quality of our supply, installation and service network, we do not accept responsibility for the workmanship or operation of any third party company.

For further information or assistance please contact:

Email: system.design@uk.bosch.com Tel: 01905751464



- [1] This jumper must be removed when connecting an external 230 V controller.
- 230 V AC Mains voltage connection, incoming
- 230 V AC Mains voltage connection, outgoing, for supplying further modules
- PH0-CH pump in hybrid box
- LR 43/44 Connection 230 V external room thermostat (230 V)
- Boiler BUS EMS BUS to boiler
- CAN CAN Power, CAN Data (connection/communication with the heat pump outdoor unit); the additional two-pole CAN connection on the left is intended for software updates
- EasyControl BUS Control unit for hybrid systems (controller)
- I1 SG Ready 1
- I4 SG Ready 2
- LIN Pump with LIN-BUS communication
- Terminal assignment:
- 1-blue, grey
- 2-black
- 3-brown
- PV Photovoltaic system (If applicable)
- SG Smart grid (If applicable)
- T0 Low loss header temperature sensor
- T1 Outside temperature sensor
- TH2 Temperature sensor return to heat pump

Hybrid manager

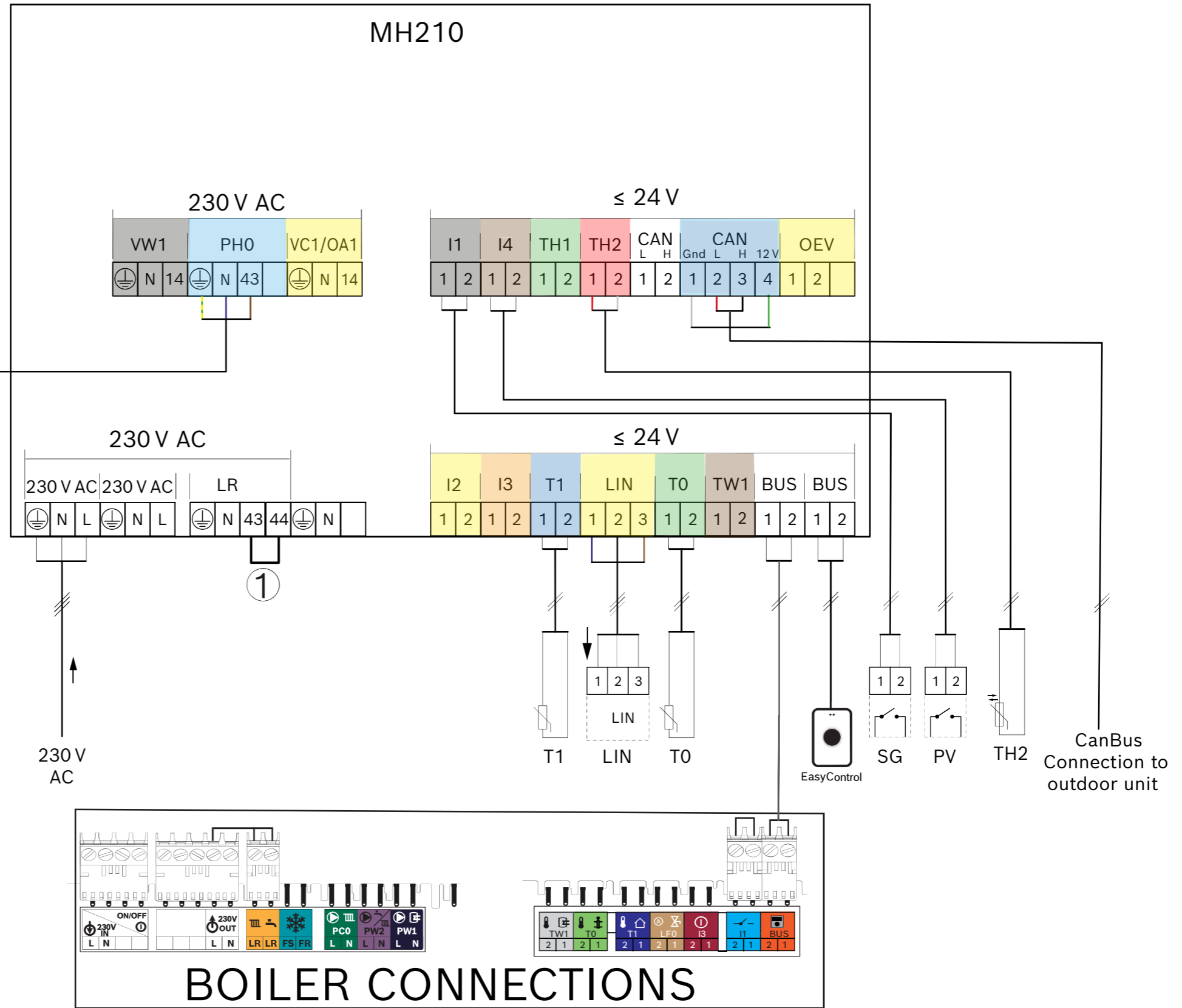

Thermostat connections

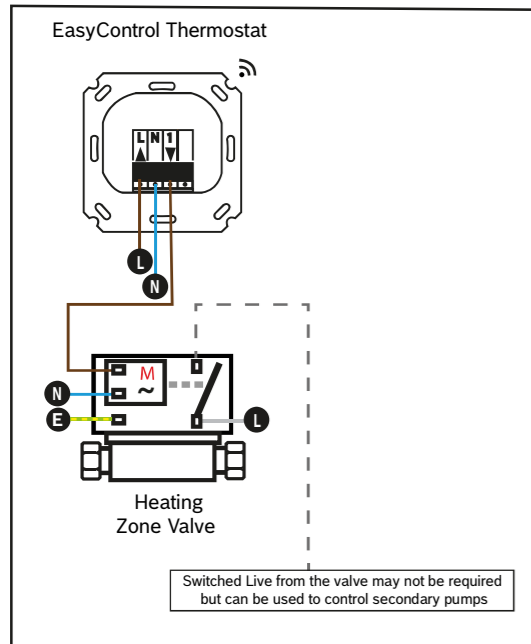

BOILER CONNECTIONS

All electrical work should be carried out by a registered engineer. Wiring must comply with the latest IET wiring regulations. Isolate the mains electricity supply before starting any work and observe all relevant safety precautions. Refer to all relevant product installation manuals for safety and installation instructions. Whilst it is always our intention to fully assist, it is essential to recognise that all information given by the company is provided in good faith and based upon the information available. Connection labels may not match those of the products installed on site. We recommend that advice should always be checked with your installer, electrician or the manufacturer of the product in question. Consequently, the company cannot be held responsible for any liability relating to the use or repetition of such information or part thereof. In addition, whilst making every reasonable effort to monitor the performance and quality of our supply, installation and service network, we do not accept responsibility for the workmanship or operation of any third party company.

Key	Description
	T1 and T0 sensors
	Isolation valve
	Drain off valve
	Magnetic filter
	Bypass
	Low loss header
	Pressure relief valve (PRV)

*At least one heating circuit should remain fully open

*Hydraulic separation with a secondary pump may be required if the hydraulic resistance of the central heating system exceeds 250 mbar at a 10 K delta T

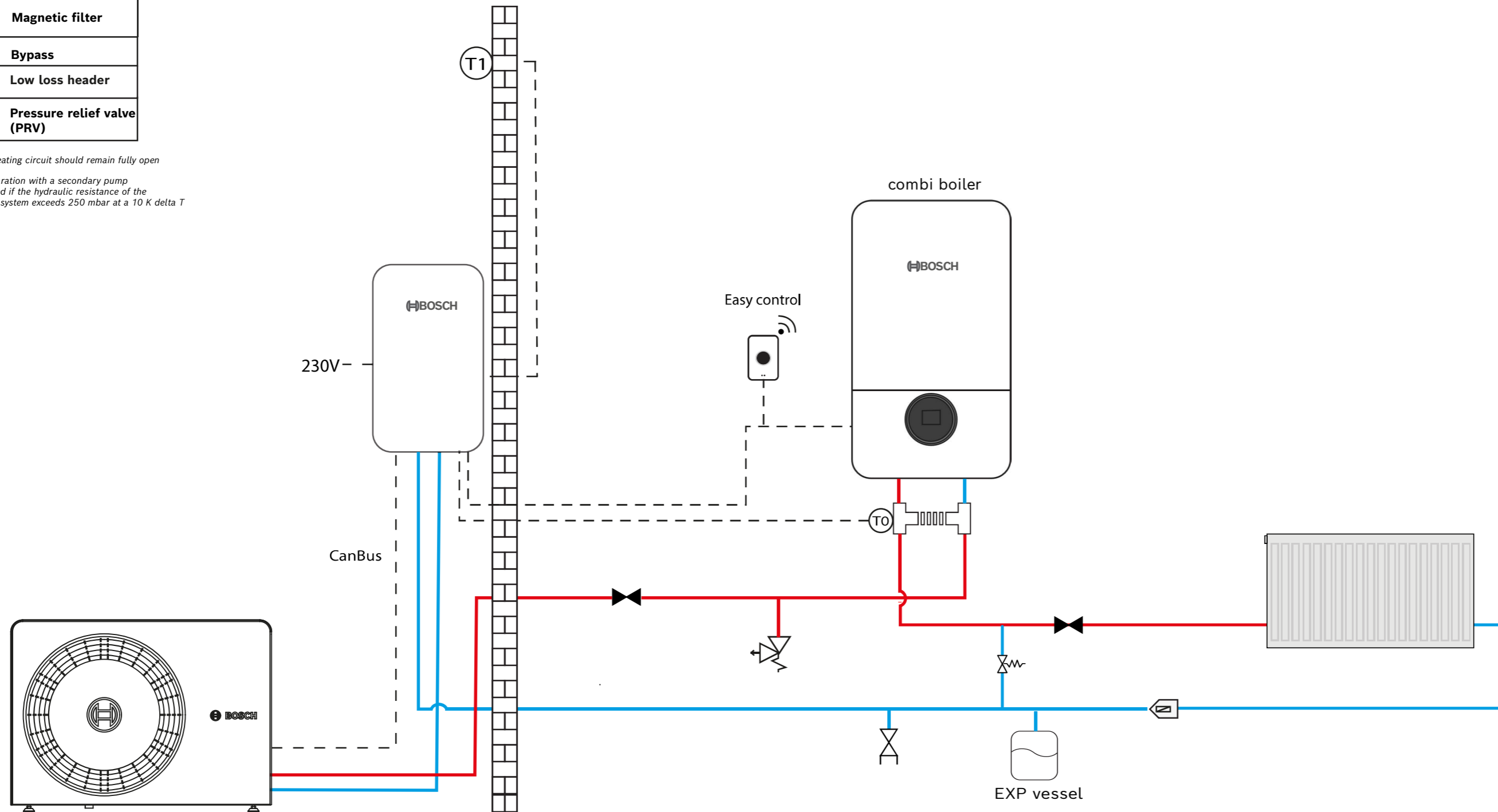

All electrical work should be carried out by a registered engineer. Wiring must comply with the latest IET wiring regulations.

Isolate the mains electricity supply before starting any work and observe all relevant safety precautions. Refer to all relevant product installation manuals for safety and installation instructions.

Whilst it is always our intention to fully assist, it is essential to recognise that all information given by the company is provided in good faith and based upon the information available. Connection labels may not match those of the products installed on site. We recommend that advice should always be checked with your installer, electrician or the manufacturer of the product in question. Consequently, the company cannot be held responsible for any liability relating to the use or repetition of such information or part thereof. In addition, whilst making every reasonable effort to monitor the performance and quality of our supply, installation and service network, we do not accept responsibility for the workmanship or operation of any third party company.

For further information or assistance please contact:
 Email: system.design@uk.bosch.com Tel: 01905751464

- [1] This jumper must be removed when connecting an external 230 V controller.
- 230 V AC Mains voltage connection, incoming
- 230 V AC Mains voltage connection, outgoing, for supplying further modules
- PH0-CH pump in hybrid box
- LR 43/44 Connection 230 V external room thermostat (230 V)
- Boiler BUS EMS BUS to boiler
- CAN CAN Power, CAN Data (connection/communication with the heat pump outdoor unit); the additional two-pole CAN connection on the left is intended for software updates
- EasyControl BUS Control unit for hybrid systems (controller)
- I1 SG Ready 1
- I4 SG Ready 2
- LIN Pump with LIN-BUS communication
- Terminal assignment:
- 1-blue, grey
- 2-black
- 3-brown
- PV Photovoltaic system (If applicable)
- SG Smart grid (If applicable)
- T0 Low loss header temperature sensor
- T1 Outside temperature sensor
- TH2 Temperature sensor return to heat pump

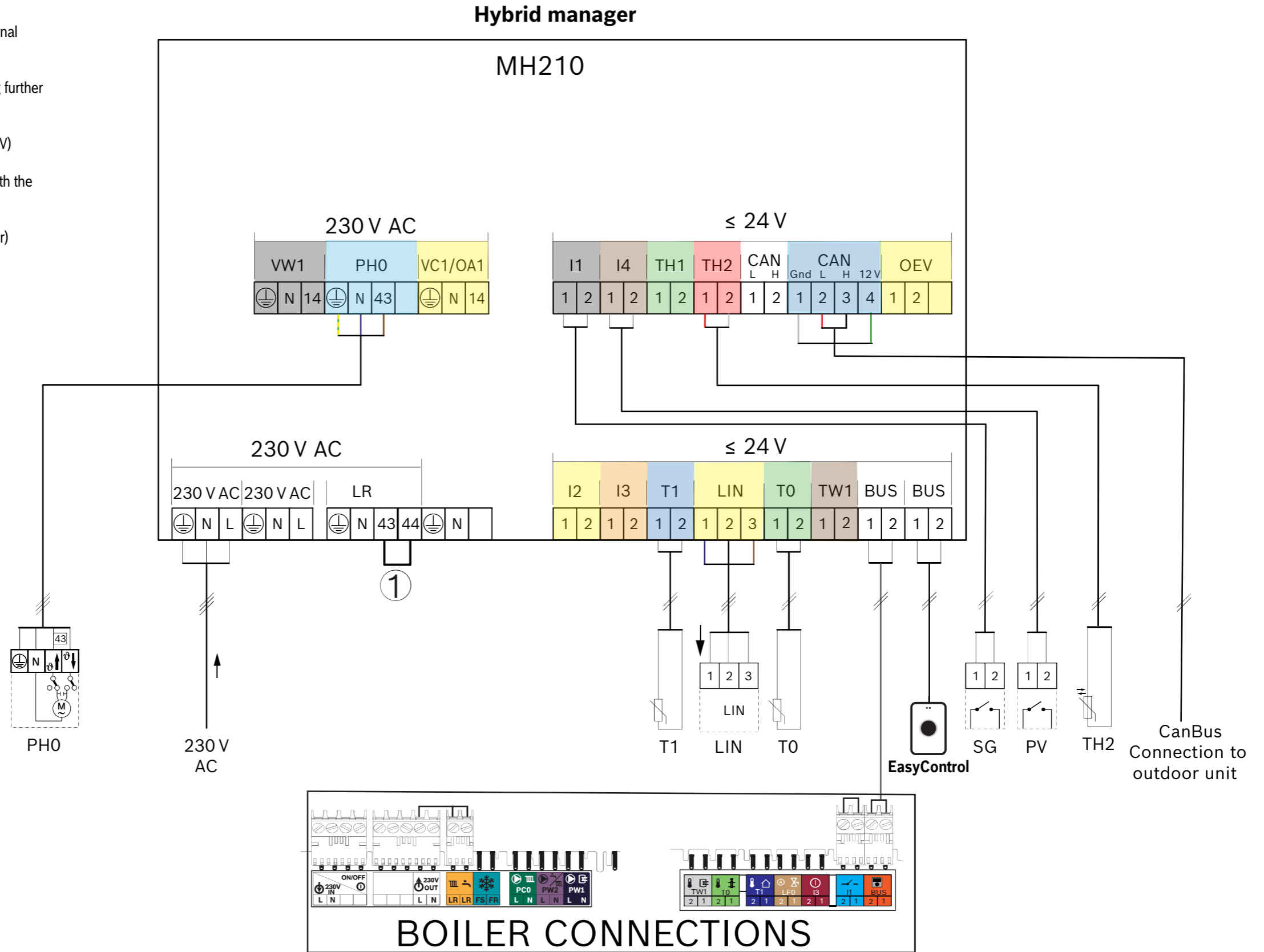

All electrical work should be carried out by a registered engineer. Wiring must comply with the latest IET wiring regulations.

Isolate the mains electricity supply before starting any work and observe all relevant safety precautions. Refer to all relevant product installation manuals for safety and installation instructions.

Whilst it is always our intention to fully assist, it is essential to recognise that all information given by the company is provided in good faith and based upon the information available. Connection labels may not match those of the products installed on site. We recommend that advice should always be checked with your installer, electrician or the manufacturer of the product in question. Consequently, the company cannot be held responsible for any liability relating to the use or repetition of such information or part thereof. In addition, whilst making every reasonable effort to monitor the performance and quality of our supply, installation and service network, we do not accept responsibility for the workmanship or operation of any third party company.

Key	Description
	T1 and T0 sensors
	Isolation valve
	Drain off valve
	Magnetic filter
	Bypass
	Low loss header
	Pressure relief valve (PRV)
	eTRV

*At least one heating circuit should remain fully open
 *Hydraulic separation with a secondary pump may be required if the hydraulic resistance of the central heating system exceeds 250 mbar at a 10 K delta T

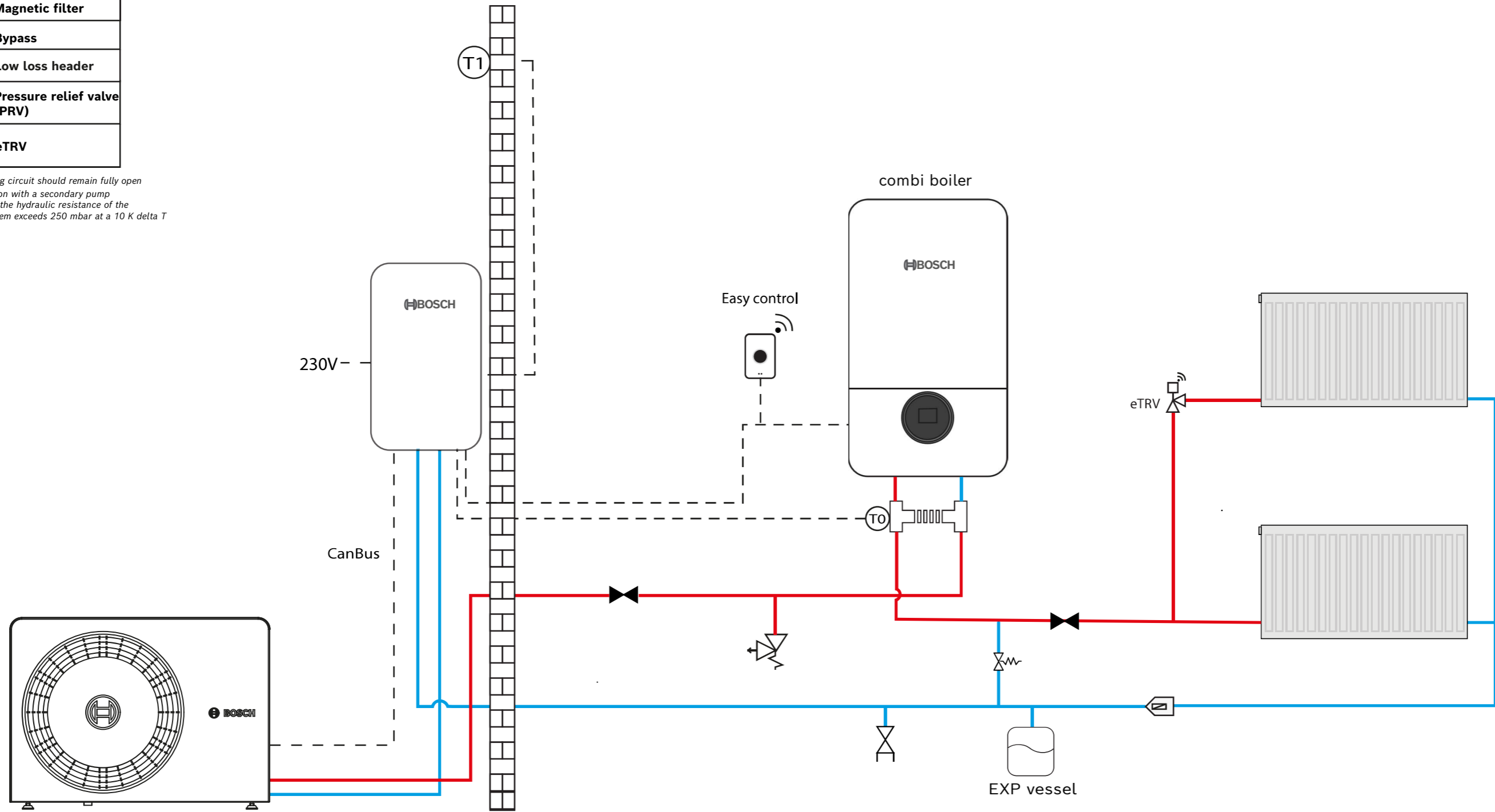

All electrical work should be carried out by a registered engineer. Wiring must comply with the latest IET wiring regulations.

Isolate the mains electricity supply before starting any work and observe all relevant safety precautions. Refer to all relevant product installation manuals for safety and installation instructions.

Whilst it is always our intention to fully assist, it is essential to recognise that all information given by the company is provided in good faith and based upon the information available. Connection labels may not match those of the products installed on site. We recommend that advice should always be checked with your installer, electrician or the manufacturer of the product in question. Consequently, the company cannot be held responsible for any liability relating to the use or repetition of such information or part thereof. In addition, whilst making every reasonable effort to monitor the performance and quality of our supply, installation and service network, we do not accept responsibility for the workmanship or operation of any third party company.

For further information or assistance please contact:
 Email: system.design@uk.bosch.com Tel: 01905751464

Hybrid manager

- [1] This jumper must be removed when connecting an external 230 V controller.
- 230 V AC Mains voltage connection, incoming
- 230 V AC Mains voltage connection, outgoing, for supplying further modules
- PH0-CH pump in hybrid box
- LR 43/44 Connection 230 V external room thermostat (230 V)
- Boiler BUS EMS BUS to boiler
- CAN CAN Power, CAN Data (connection/communication with the heat pump outdoor unit); the additional two-pole CAN connection on the left is intended for software updates
- EasyControl BUS Control unit for hybrid systems (controller)
- I1 SG Ready 1
- I4 SG Ready 2
- LIN Pump with LIN-BUS communication
- Terminal assignment:
- 1-blue, grey
- 2-black
- 3-brown
- PV Photovoltaic system (If applicable)
- SG Smart grid (If applicable)
- T0 Low loss header temperature sensor
- T1 Outside temperature sensor
- TH2 Temperature sensor return to heat pump

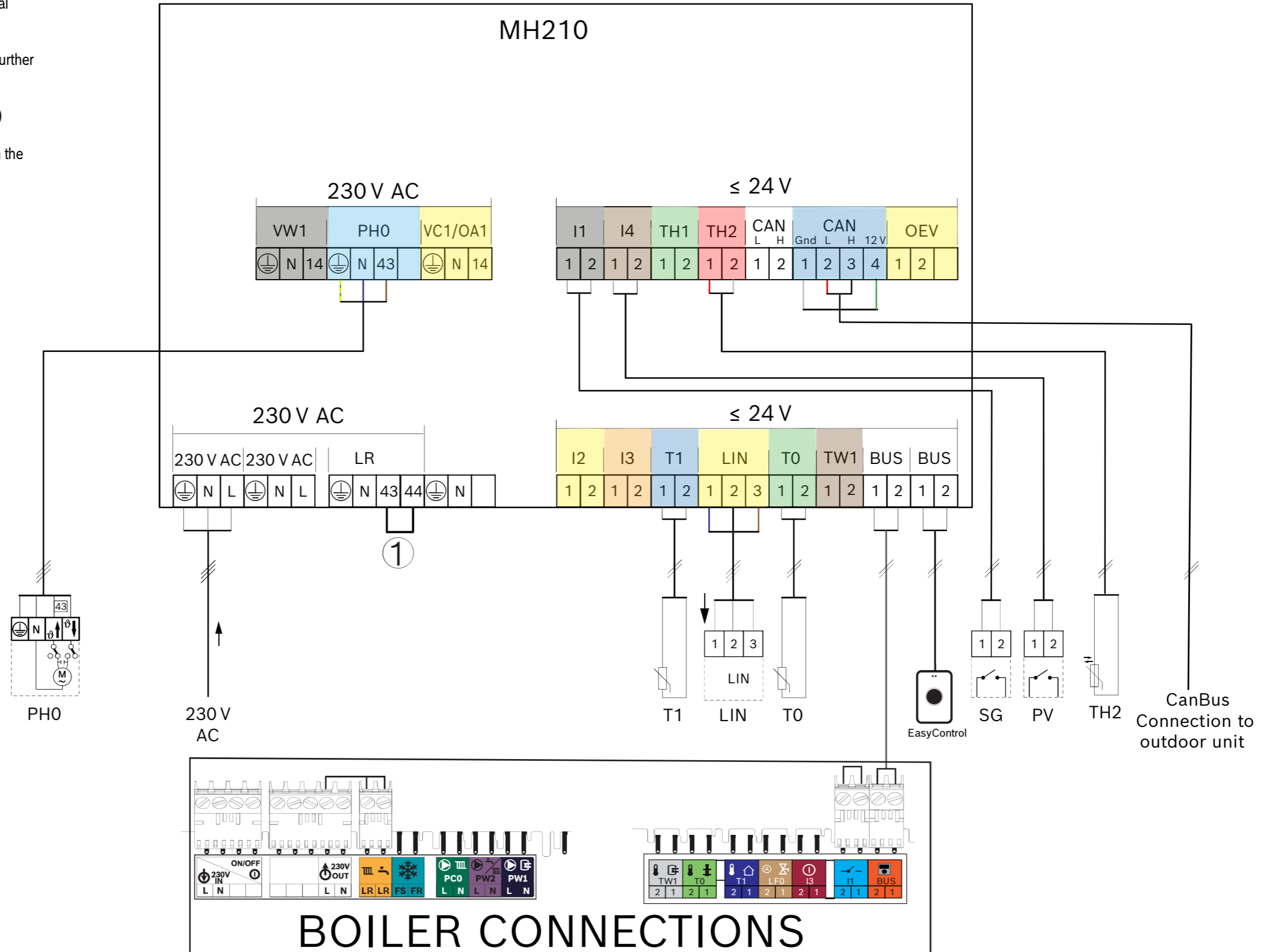

All electrical work should be carried out by a registered engineer. Wiring must comply with the latest IET wiring regulations.

Isolate the mains electricity supply before starting any work and observe all relevant safety precautions. Refer to all relevant product installation manuals for safety and installation instructions.

Whilst it is always our intention to fully assist, it is essential to recognise that all information given by the company is provided in good faith and based upon the information available. Connection labels may not match those of the products installed on site. We recommend that advice should always be checked with your installer, electrician or the manufacturer of the product in question. Consequently, the company cannot be held responsible for any liability relating to the use or repetition of such information or part thereof. In addition, whilst making every reasonable effort to monitor the performance and quality of our supply, installation and service network, we do not accept responsibility for the workmanship or operation of any third party company.

For further information or assistance please contact:
 Email: system.design@uk.bosch.com Tel: 01905751464

Key	Description
	T1 and T0 sensors
	Isolation valve
	Drain off valve
	Bypass
	Magnetic filter
	Low loss header
	Pressure relief valve (PRV)
	230 V controls
	Blending valve

*At least one heating circuit should remain fully open

*Hydraulic separation with a secondary pump may be required if the hydraulic resistance of the central heating system exceeds 250 mbar at a 10 K delta T

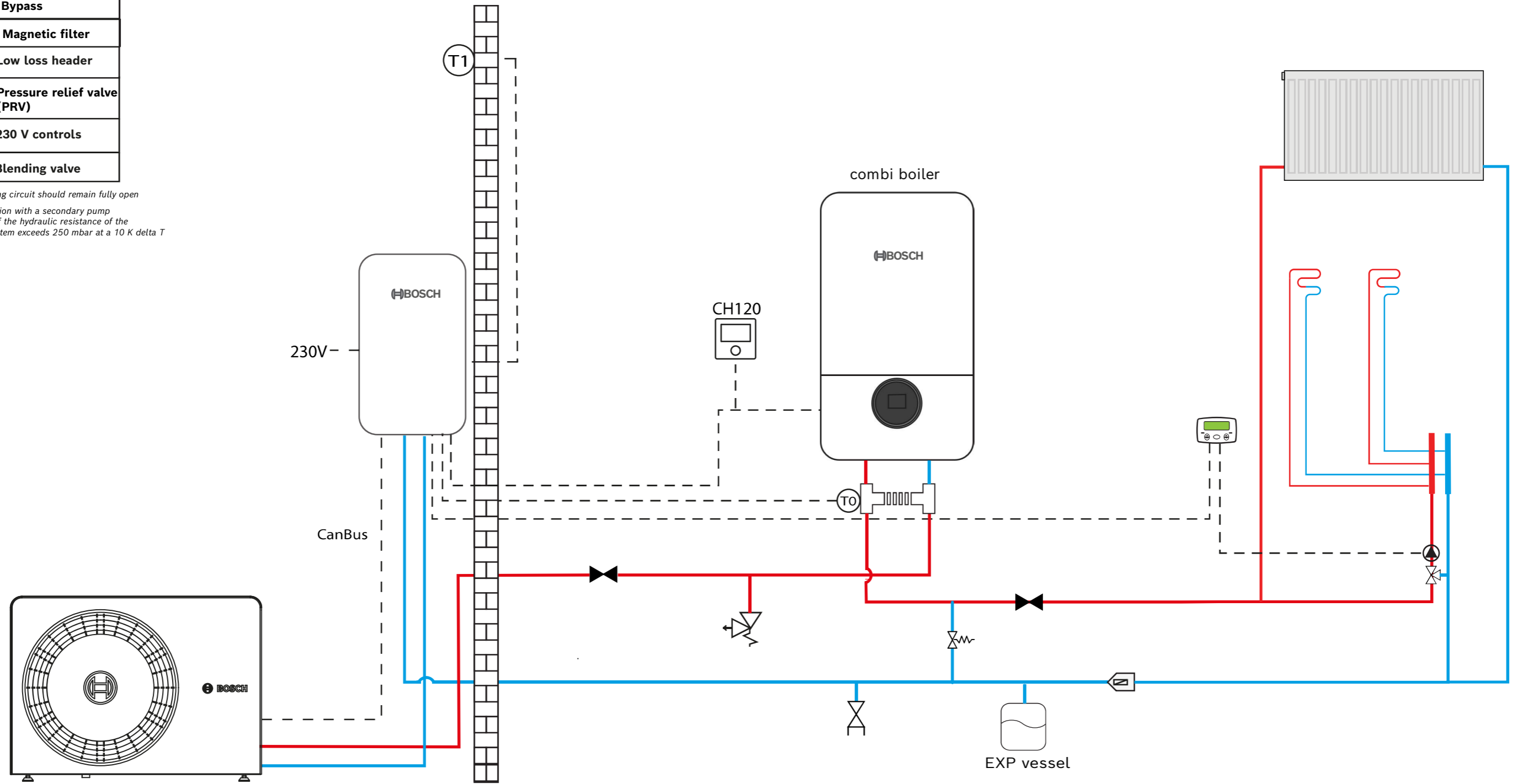

All electrical work should be carried out by a registered engineer. Wiring must comply with the latest IET wiring regulations.

Isolate the mains electricity supply before starting any work and observe all relevant safety precautions. Refer to all relevant product installation manuals for safety and installation instructions.

Whilst it is always our intention to fully assist, it is essential to recognise that all information given by the company is provided in good faith and based upon the information available. Connection labels may not match those of the products installed on site. We recommend that advice should always be checked with your installer, electrician or the manufacturer of the product in question. Consequently, the company cannot be held responsible for any liability relating to the use or repetition of such information or part thereof. In addition, whilst making every reasonable effort to monitor the performance and quality of our supply, installation and service network, we do not accept responsibility for the workmanship or operation of any third party company.

For further information or assistance please contact:
 Email: system.design@uk.bosch.com Tel: 01905751464

- [1] This jumper must be removed when connecting an external 230 V controller.
- 230 V AC Mains voltage connection, incoming
- 230 V AC Mains voltage connection, outgoing, for supplying further modules
- PH0-CH pump in hybrid box
- LR 43/44 Connection 230 V external room thermostat (230 V)
- Boiler BUS EMS BUS to boiler
- CAN CAN Power, CAN Data (connection/communication with the heat pump outdoor unit); the additional two-pole CAN connection on the left is intended for software updates
- CON BUS Control unit for hybrid systems (controller)
- I1 SG Ready 1
- I4 SG Ready 2
- LIN Pump with LIN-BUS communication
- Terminal assignment:
- 1-blue, grey
- 2-black
- 3-brown
- PV Photovoltaic system (If applicable)
- SG Smart grid (If applicable)
- T0 Low loss header temperature sensor
- T1 Outside temperature sensor
- TH2 Temperature sensor return to heat pump

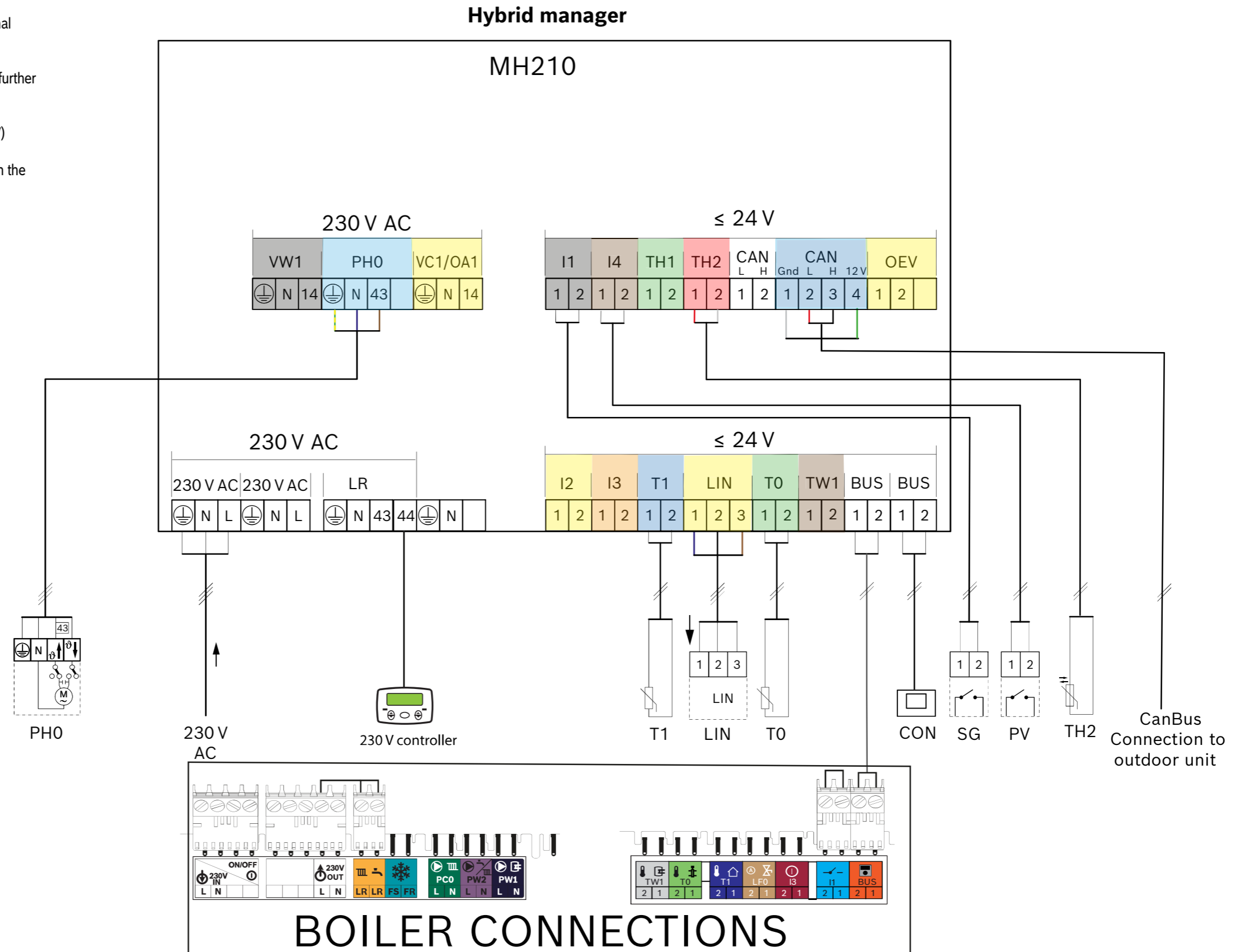

All electrical work should be carried out by a registered engineer. Wiring must comply with the latest IET wiring regulations.

Whilst it is always our intention to fully assist, it is essential to recognise that all information given by the company is provided in good faith and based upon the information available. Connection labels may not match those of the products installed on site. We recommend that advice should always be checked with your installer, electrician or the manufacturer of the product in question. Consequently, the company cannot be held responsible for any liability relating to the use or repetition of such information or part thereof. In addition, whilst making every reasonable effort to monitor the performance and quality of our supply, installation and service network, we do not accept responsibility for the workmanship or operation of any third party company.

Key	Description
	T1 and T0 sensors
	Isolation valve
	Drain off valve
	Bypass
	Magnetic filter
	Low loss header
	Pressure relief valve (PRV)
	230 V controls
	Two port valve

*At least one heating circuit should remain fully open

*Hydraulic separation with a secondary pump may be required if the hydraulic resistance of the central heating system exceeds 250 mbar at a 10 K delta T

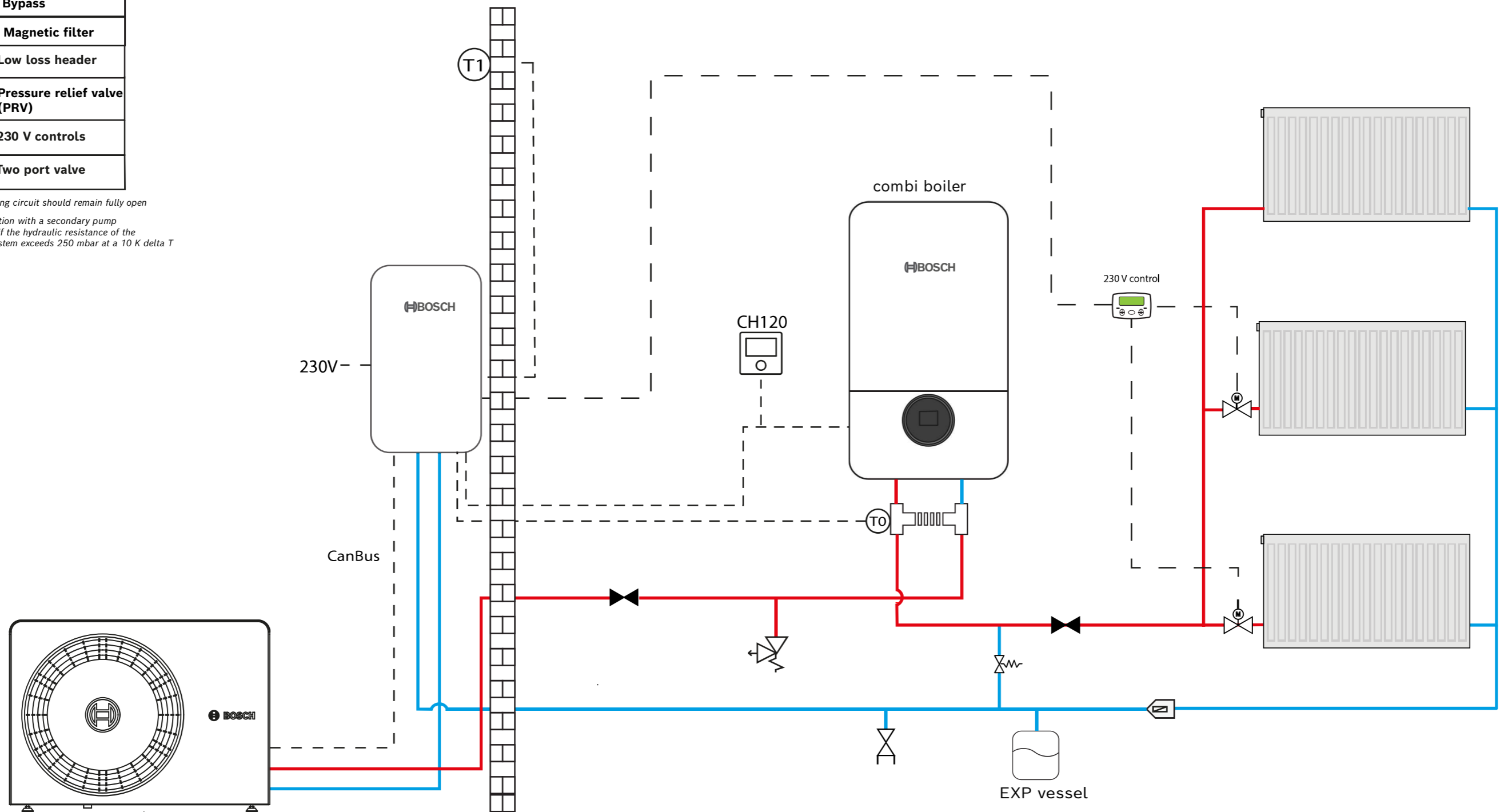

All electrical work should be carried out by a registered engineer. Wiring must comply with the latest IET wiring regulations.

Isolate the mains electricity supply before starting any work and observe all relevant safety precautions. Refer to all relevant product installation manuals for safety and installation instructions.

Whilst it is always our intention to fully assist, it is essential to recognise that all information given by the company is provided in good faith and based upon the information available. Connection labels may not match those of the products installed on site. We recommend that advice should always be checked with your installer, electrician or the manufacturer of the product in question. Consequently, the company cannot be held responsible for any liability relating to the use or repetition of such information or part thereof. In addition, whilst making every reasonable effort to monitor the performance and quality of our supply, installation and service network, we do not accept responsibility for the workmanship or operation of any third party company.

For further information or assistance please contact:
 Email: system.design@uk.bosch.com Tel: 01905751464

Hybrid manager

- 230 V controller on/off 230 VAC external controller
- 230 V AC Mains voltage connection, incoming
- 230 V AC Mains voltage connection, outgoing, for supplying further modules
- PH0-CH pump in hybrid box
- LR 43/44 Connection 230 V external room thermostat (230 V)
- Boiler BUS EMS BUS to boiler
- CAN CAN Power, CAN Data (connection/communication with the heat pump outdoor unit); the additional two-pole CAN connection on the left is intended for software updates
- CON BUS Control unit for hybrid systems (controller)
- I1 SG Ready 1
- I4 SG Ready 2
- LIN Pump with LIN-BUS communication
- Terminal assignment:
1-blue, grey
2-black
3-brown
- PV Photovoltaic system (If applicable)
- SG Smart grid (If applicable)
- T0 Low loss header temperature sensor
- T1 Outside temperature sensor
- TH2 Temperature sensor return to heat pump

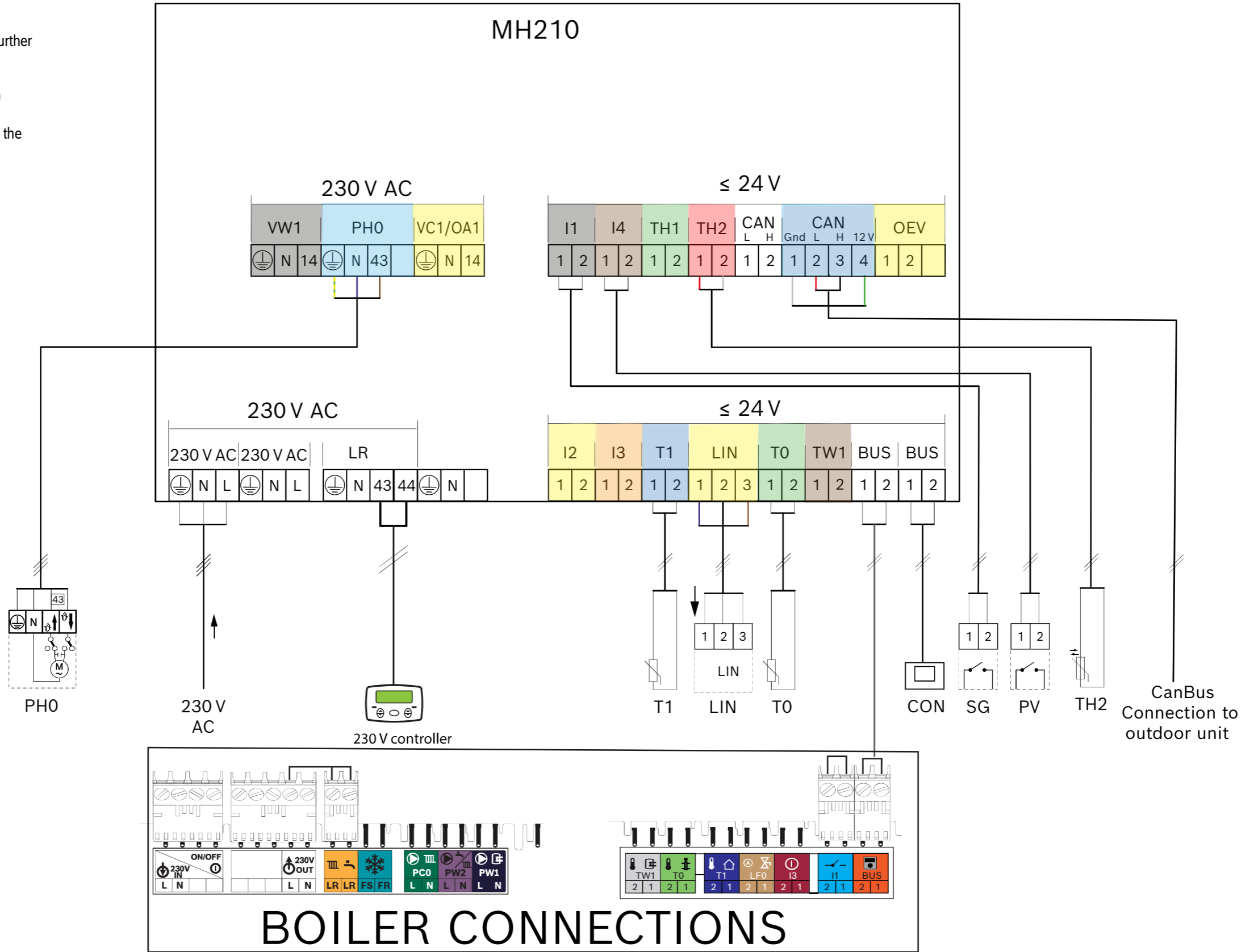

All electrical work should be carried out by a registered engineer. Wiring must comply with the latest IET wiring regulations. Isolate the mains electricity supply before starting any work and observe all relevant safety precautions. Refer to all relevant product installation manuals for safety and installation instructions. Whilst it is always our intention to fully assist, it is essential to recognise that all information given by the company is provided in good faith and based upon the information available. Connection labels may not match those of the products installed on site. We recommend that advice should always be checked with your installer, electrician or the manufacturer of the product in question. Consequently, the company cannot be held responsible for any liability relating to the use or repetition of such information or part thereof. In addition, whilst making every reasonable effort to monitor the performance and quality of our supply, installation and service network, we do not accept responsibility for the workmanship or operation of any third party company.