

*Merry  
Christmas*

*from*

 **WORCESTER**  
Bosch Group



**A first look at our NEW  
intelligent heating controls**

# 5 year guarantee\* and 5 years' peace of mind

now on ALL Greenstar  
gas-fired boilers.

To find out more visit [www.worcester-bosch.co.uk/5year](http://www.worcester-bosch.co.uk/5year)



Which? Best Buy Awards apply to Greenstar gas-fired boiler range only.

\*Terms and conditions apply.

# Welcome

from Steve Lister



Welcome to the December issue of Installer's Choice.

As ever, this year has been another hugely eventful one for all at Worcester. From attracting record numbers of visitors and training delegates to our double-decker stand at Ecobuild, to

the launch of our innovative new Wave smart control, we've had plenty to shout about. To end the year with the news that we have topped the Which? boiler report for the fourth year in succession was not only a huge cause for celebration, but also a remarkable testament to those of you who have helped us along the way.

With the heating season well underway, this exciting month gives us the exciting opportunity to preview our NEW generation of controls that everyone will be comfortable with. We have also put together an extensive controls leaflet, which is inserted in this month's Installer's Choice, to give you a comprehensive breakdown of the various options available. Our new range of intelligent & simple to use controls, are quick and easy to install, and are backed up by the quality & reliability you can expect from Worcester. To find out more, turn to pages 6 and 7.

The heating industry has been subjected to a number of changes and challenges this year, not least because many saw 2013 as a tough act to follow. To read the views of Carl Arntzen, our Managing Director, turn to pages 8 and 9.

Finally, we're well aware of just how beneficial it can be to have the products you fit on a daily basis installed in your own home. In recognition of this, our cash-back initiative continues to give you access to a number of financial incentives whenever you fit a Worcester product in your own home. Find out how you can benefit by reading pages 9 and 10.

We hope you enjoy the magazine and wish you a very Merry Christmas and a Happy New Year.

**Steve Lister**  
Sales and Marketing Director

## CONTENTS

Pages 4 & 5  
The latest news from Worcester

Pages 6 & 7  
Preview the next generation of heating controls

Pages 8 & 9  
Carl Arntzen reflects on 2014

Pages 10 & 11  
Cash-back promotion for installations in own home

Page 12  
**Be Our Guest:** OFTEC

Page 13  
**Green page:** E2020 Award winner, Mark Sellwood

Page 15  
**Training focus:** Introducing OFTEC 50

Page 16  
Technical Q&A

Page 17  
Win with Worcester

Pages 18  
Keep in Touch



## Social Housing Conference encourages future installations

Last month we hosted a Social Housing Conference in London to give specification managers an insight into the Worcester view of the market now, and going forward. During the day, speeches were given by representatives from the Homes and Communities Agency, DECC and by Gavin Williamson MP, Parliamentary Private Secretary to the Prime Minister.

This conference helped to inform people on the heating solutions available for social housing and will hopefully stimulate an interest in installing Worcester products.



## Worcester Accredited Installer named top tradesman



Worcester Accredited Installer, Raymond McKnight, of Hillview Heating and Plumbing in Newtown Abbey, Belfast, has been named Screwfix and the Daily Star's Britain's Top Tradesman 2014.

Raymond wowed at the regional heats before beating 10 other

competitors in a Wembley Stadium final, where he walked away with the coveted title and a Toyota van.

On behalf of everyone at Worcester, we would like to congratulate Raymond on such a fantastic achievement.

## Celebrations for college partnership

Our South West Mobile Trainer, Brian Haines picked up an award at Camborne College's Apprentice Awards earlier this month. The accolade is a reflection of the ongoing training and support provided by private companies such as Worcester to help upcoming installers.

Speaking of his award win Brian commented: "I was extremely proud to collect this award, it recognises the hard work of everyone involved in the scheme and shows our commitment to providing students with the best experience possible."

"We strive to supply second and third year students with everything they need to complete their NVQ Plumbing qualifications and ensure they can fit products confidently."

## Boiler registration just one click away

We are committed to providing you with the tools needed to make your job as easy as possible, and with more of you turning to your phones for guidance, we are developing our brand new Guarantee Registration app which provides you with a simple solution to registering one of our boilers following an installation. By scanning the boiler's QR code, all the appliance's information is automatically populated on the form, requiring you simply to fill out the property's details.

The guarantee registration app will allow you to complete the registration of our Greenstar boilers, Greenstar System Filter and Wave smart control. This process has been designed to save you time and minimise the paperwork which you are taking home at the end of the day.

The new app will be available to download very soon.



## Salus Plug-In Heating Controls and Worcester Greenstar Condensing boilers

A number of field issues have been identified on the functionality of Worcester Greenstar boilers when used in conjunction with the Salus plug-in fascia mounted receiver and wall mounted transmitter, Product ST620WBC. The product range is marketed by Salus as the Mix and Match range and effectively allows a base unit to be attached to the fascia of a Worcester Greenstar boiler and one of a choice of five different room temperature controllers to be connected to the base unit via an RF signal.

It has been found that when the controller is fitted to a Greenstar Compact Combination boiler the appliance components can be affected by the Salus base or fascia mounted unit with the boiler failing to operate correctly. Salus are undertaking ongoing tests to try and find a solution to this issue.

The boilers affected by this combination are the Greenstar CDi compact series and the Si Compact series, model numbers and part numbers;

- 28 CDi Compact Natural Gas 7 716 130 234
- 28 CDi Compact LPG 7 716 130 237
- 32 CDi Compact Natural Gas 7 716 130 235
- 32 CDi Compact LPG 7 716 130 238
- 36 CDi Compact Natural Gas 7 716 130 236
- 36 CDi Compact LPG 7 716 130 239
- 25 Si Compact Natural Gas 7 716 130 230
- 25 Si Compact LPG 7 716 130 231
- 30 Si Compact Natural Gas 7 716 130 232
- 30 Si Compact LPG 7 716 130 233

There are alternative options available to you, including the installation of a wired version or a Worcester plug in controller. For further details, please contact our Technical Helpline on 0330 123 3366 or e-mail, technical.enquiries@uk.bosch.com

## Installer Tweets of the Month

Our Twitter feed (@heatingyourhome) is always a hive of activity, with many of you getting in touch to notify us of everything from notable installations to technical questions and queries. To showcase your support we have put together a selection of our recent top tweets:

 **M Broer Heating**  
@mbroerheating

Thanks to @heatingyourhome for the hat, it's a bit small for my head. But I've found someone who seems to like it.



 **Heatforce**  
@heatforcewales

Come and see our new heating showroom featuring Worcester boilers and Stelrad radiators @heatingyourhome @Stelrad



 **Campbell Copeland**  
@herkessoft

Getting my @heatingyourhome Greenstar 30CDi System boiler, Greenstore SC-210, Greenstar System Filter & Wave controller installed next week!

 **Scott Findlay**  
@Scott\_FindlayPH

@heatingyourhome Annoying outdated #heating controls? Don't get ANGRY-switch to the #Wave - Smart AND Simple





The new Greenstar Comfort controls will join the Wave smart heating controller which was launched earlier this year.

## Preview: Controls that **everyone** is comfortable with.

Following the launch of our state-of-the-art Wave smart controller back in September, this January sees us improve our controls portfolio even further with the preview of a whole new family of controls designed to make life comfortable for both you and your customers. We have designed this new generation of controls after listening to feedback from a number of you and your customers.

Our brand new Greenstar Comfort range is a collection of intelligent and simple to use controls, quick and easy to install, and backed up by the quality and reliability you can expect from Worcester products. Not only that, but when one of our new controls is fitted with one of our Greenstar boilers at time of installation, it benefits from the same guarantee length as the boiler itself.

With fuel prices on the rise and many of your customers wanting complete flexibility over their central heating and hot water whilst being able to reduce their fuel consumption, the

Comfort range boasts a series of plug-in options for a quick installation. We have designed and manufactured each of the controls specifically for our expansive Greenstar boiler range, which means you and your customers can benefit from full compatibility, reliability, and peace of mind.

Each Comfort control allows your customers to benefit from an intuitive dial-controlled menu for smooth navigation of all heating and hot water functions. This not only makes it even simpler to control the heating but also allows for improved efficiency and increased comfort

thanks to the ability to programme different times.

Unlike other options on the market, the Greenstar Comfort range of controls offers wireless load compensation, which not only ensures installation flexibility, but also has the potential to significantly reduce fuel consumption. The new control options are also ErP ready, with the room ready controls boasting 3 per cent uplift in efficiency under the forthcoming ErP Directive.

Ensuring there is a Comfort control available for every requirement, the new range boasts three different options.

### Greenstar Comfort twin channel programmer and thermostat

Capable of delivering a different central heating and domestic hot water (DHW) programme for each day of the week, the twin channel programmer also gives the end user the chance to set and adjust three separate time periods for each day. With this product the customer can utilise their existing room thermostat.

### Greenstar Comfort I RF twin channel programmer

As well as the impressive line-up of features the twin channel programmer has, the RF variant of our Comfort range offers the added benefit of an extremely reliable RF signal with Radio Signal Strength Indication (RSSI) menu. Crucially for installers the Comfort RF model has a pre-paired receiver and sender; making the device simple to fit.

The addition of load compensation for an additional 3% efficiency gain under the ErP directive not only enhances efficiency levels, but is

also a feature no other controls manufacturer offers from a wireless boiler control.

### Greenstar Comfort II RF programmable room thermostat

The premium model within our new Comfort range, the Comfort II RF programmable room thermostat, builds on the advanced capabilities of the Comfort I, but with the addition of yet more performance enhancing features including a super bright backlit display.

The Comfort II allows the boiler's central heating and DHW to be programmed and controlled from the thermostat itself, which is perfect for those installations where the boiler isn't the most accessible.

In addition, not only does the Comfort II display fault codes, but it also allows you to access the boiler's fault history remotely; which offers a comprehensive profile of any issues the boiler may have had previously. To improve performance further,

adjustments can be made to the heating system from the Comfort II, to improve its efficiency.

On the launch of our new Comfort range of controls, Martyn Bridges our Director of Marketing and Technical Support commented: "Despite some of the recent innovations in the market for heating and hot water controls, we're aware that the vast majority of controls installed remain the most basic of mechanical options. It is vitally important that manufacturers and installers continue to educate their customers on the benefits of using more intelligent programmers to benefit from greater comfort and the potential for reduced energy bills.

"By sitting alongside the Wave, our Comfort range means we can now cater for a wide variety of homeowner preferences whilst making it as simple as possible for installers to fit intelligent controls."

Please refer to the accompanying leaflet to see what the new Comfort controls are replacing in January 2015.



# Reflecting on 2014

**As we approach the end of what has been an interesting year for the heating industry as whole, Carl Arntzen, our Managing Director, reflects on this year and offers his views on what could be in store for the industry in 2015.**



“Having experienced a strong 2013, this year got off to a very good start. That said, the slowing down of such strong momentum was inevitable and typified this year’s market from the second quarter onwards. The fourth quarter of 2013 was exceptional, so securing growth on last year, particularly the double digit growth we experienced at Worcester, was always going to be a challenge.

“To understand the year and where to go from here, it’s important to understand reasons behind some of the challenges faced in 2014. The 2013 market was heavily influenced by the Government’s ECO scheme, which accounted for a huge number of boiler installations; bringing work forward from this year as the incentive made the investment

more appealing. Unfortunately, this resulted in a lower level of opportunity for a number of installers this year.

### Points of impact

“Certain factors have distorted the market. Government incentive programs can be welcome for a time, but have a tendency to create a ‘boom-bust’ scenario, which isn’t helpful. Lower levels of eco funding and the seven week long Green Deal Home Improvement Fund, proved to be short-lived which left us in the unfortunate position whereby most, if not all, initiatives funded by the Government create short term distortions to the market. This makes trying to plan any business over a three, five or even ten year period incredibly challenging.

“The domestic RHI has been disappointing, yet the frustration is that the aspiration behind the initiative is perfectly sound. Enhancing the way

we heat our housing stock is one of the major routes to tackling climate change and reducing emissions. We know we need to take on the challenge, but the practicalities of doing so have so far proved difficult. How we go about achieving our emissions targets is very inconsistent at the moment, and a long term plan would be much more suitable. One idea might be to look towards the automotive industry that was in a similar position seven or eight years ago, before a long term plan to reduce carbon emissions was put in place.

“Renewable markets have been affected by the Government’s green initiatives,

and another factor is the nature of the UK’s gas infrastructure which makes it very difficult to see technologies such as heat pumps displacing gas-fired appliances on a large scale. We’re now approaching the tenth anniversary of condensing boilers being made mandatory and with 50-55% of domestic boilers installed in UK homes now condensing, we still have work to do if we’re to convert the remainder of homes. In spite of all the renewable policy frameworks I see at the moment, there probably won’t be a dramatic shift on what is installed today over the next five years.

### Efficiency enhancements

“In terms of efficiency enhancements, the main area we’re excited about is controls, especially with the launch of our own Wave smart control, and the shift towards smart homes.

The smart home is an exciting time for the whole Bosch Group as we see the potential for greater alignment of heating technologies with other household appliances.

“The new build sector has also started to recover and we’re now in a

position where there is strong growth in the market for new homes. The Prime Minister’s recent proposal for an increase in new houses per year is encouraging and as many as 130,000 new homes are being built every year. While this total is not huge, it will still create demand for a variety of heating and plumbing products, which should be seen as a massive opportunity for our industry.

“Shale gas and fracking has transformed the US and has potential to transform the UK energy market as gas reserves are running low. With energy and political landscapes changing, the market for heating technologies over Europe has adapted in line with this. The fear that gas reserves were running out fuelled renewables but this is now changing as gas has become more available in the long term.

“It’s important for installers not to feel discouraged by the slightly slower market in the latter half of 2014 and to go back to basics by simply maintaining a good quality of service and giving customers good value. I’d encourage installers to keep on top of new technology areas such as controls and keep an eye out for the new opportunities on the horizon in 2015.”





## Cash back promotion for installations in your own home

Committed to energy efficiency, we have been at the forefront of heating and hot water systems for many years, developing high quality renewable technologies that help homeowners to reduce their fuel costs as well as protecting the environment.

And from talking to many of you, we know that the experience of installing a product in your own home can help you to sell that technology onto your customers more easily. This has prompted us to extend our cash-back promotion and encourage you to install products in your own home.

**From January 2015 we are increasing the cash back you can receive when you install Worcester products in your own home, giving you the opportunity to claim £250 for Greenstar gas- or oil-fired boilers and £25 when installing the innovative Wave or any one of our new Greenstar Comfort controls.**

Installing our products in your own home can bring significant benefits to you and your business. With daily, hands-on use, you will have the opportunity to demonstrate the cost-

### The other cash back offers available are detailed below:

- **£150** for Greenstar gas- or oil-fired boilers
- **£150** for a Greenstore unvented cylinder
- **£350** for Greenstore ground source heat pumps
- **£300** for Greensource air to water heat pumps
- **£300** for Greenskies Solar-Lux 12 solar thermal systems
- **£200** for Greenskies solar-lifestyle and solar-lux 6 solar thermal systems
- **£100** for Greenskies solar-lito thermal systems
- **£100** for Greensource air to air heat pumps
- **£50** for Greenskies Lito mini (1m<sup>2</sup>) solar-lito thermal systems
- **£50** for a Greenstore solar compatible unvented cylinder (when installed at the same time as a solar thermal system)
- **£25** for a Wave smart controller or Greenstar Comfort controls

savings you experience to potential customers – something which can add value to your business.

Don't just take our word for it - a

number of installers who have taken up this fantastic offer spoke to us about their installations and the benefits of fitting Worcester products in their own properties.

## Graham Peachey of G R Peachey, Kent.

As part of an extension to his 1980's detached property, Kent-based installer Graham Peachey, decided to install a Greenstar 24 Ri boiler alongside Greenskies solar panels and a Greenstore 210 litre solar compatible unvented, to ensure his five-bedroom home had a sufficient heating and hot water system.

Speaking of the installation Graham comments: "I always offer clients the chance to look at the products in my own home, so that they know what they will be getting. Doing this has certainly helped them to understand the product, how it works and its



benefits. In fact, a couple of my customers have had Greenstore solar compatible unvented cylinders installed with a view to

adding the solar system to it at a later date. This has definitely come from being able to show them the package face-to-face."

## Charles Rowlands of Charles Rowlands Ltd, Llanuwchllyn.

Loyal supporter of Worcester, Charles decided to 'go green' by installing a range of high-efficiency and renewable products in his own home; "I recommend Worcester's products to all my customers, so it was the obvious choice to install a Worcester Greenstar 18/25 Utility System boiler in my garage, alongside Greenskies solar panels on my roof and a Greenstore 300 litre solar compatible unvented cylinder. We fitted the pump and controls in the garage before taking out the old boiler which was in our utility room.



"I've had quite a few customers enquiring about how they can save money by installing a similar system to my own and I intend to run open days to let people see the system for themselves. Most importantly, my new

heating system will help save the environment for my children and their children's future".

If you have recently fitted Worcester products in your own

home and would like to feature in an upcoming issue of Installer's Choice, please feel free to get in touch and tell us about your installations.





Jeremy Hawksley, General Director at OFTEC, explains how OFTEC has evolved in line with the changing face of domestic heating and expanded its service offering to heating engineers.

## OFTEC SETS THE PACE FOR THE FUTURE



OFTEC registration is proof of competence and by displaying the distinctive OFTEC logo, technicians can underline the quality of their work. This provides consumers with peace of mind that their heating system will be installed and maintained by someone who really knows what they are doing - a big plus with so many 'cowboys' out there.

Amongst the many other benefits of OFTEC registration, technicians can self-certify installations in accordance with Building Regulations in England, Wales, Isle of Man and the Channel Islands, avoiding the time and expense of going through local authority building control.

We remain fully committed to supporting our technicians and OFTEC's expert staff can provide free technical advice via phone, fax or email. OFTEC also has a network of experienced regional inspectors who technicians can approach for help and guidance. Essential updates for technical books are provided via email.

With the business world becoming ever more competitive, OFTEC also offers technicians a range of consumer friendly marketing leaflets to promote their business, plus free listings on the OFTEC website ([www.oftec.co.uk](http://www.oftec.co.uk)) and Competent Persons Forum websites.

We recognise costs are a key concern for any business and, in addition to

offering discounts on equipment through OFTEC Direct, OFTEC registration also includes a free debt collection facility and discounts on other useful services such as business insurance.

And to keep up with the latest industry news and developments, registered technicians receive free copies of the quarterly Oil Installer magazine and OFTEC's monthly e-newsletter, as well as invitations to exclusive OFTEC events.

All this provides a compelling package of financial, technical and business benefits to help new and existing registered technicians stay ahead of the game and secure the future of their business.

### Embracing renewables

With the latest figures showing that oil prices are at a four year low, oil looks set to remain one of the cheapest and most efficient ways to heat off-grid homes.

The cost difference between oil and mains gas has narrowed throughout the last year with oil now just 2% more expensive than gas to heat a typical three bedroom home in Great Britain. If this trend continues it is likely that oil will actually become cheaper than gas in the near future. Oil also remains considerably cheaper than LPG, currently coming in around 40%

less expensive. While this undoubtedly points to a positive future for oil but we also recognise the increasing role domestic renewable heat will play in the longer term. To this end, OFTEC has introduced new classes of registration for solar thermal systems and heat pumps, with plans to extend this to cover biomass next year.

Installation businesses can now join OFTEC's combined Competent Persons Scheme (CPS) and Microgeneration Certification Scheme (MCS). By registering with these schemes, existing OFTEC technicians can add renewables to their oil heating business to expand customer reach, while installers already working in the renewables sector will benefit from the excellent value for money OFTEC renewable registration provides.

Registration costs are currently amongst the lowest on the market and OFTEC is offering a 25% discount for the first year, bringing the price down to £475 per business for one renewable scope of registration and £550 for two. This includes the MSC licence fee and free, expert technical support in renewables.

The oil heating industry undeniably faces challenges but by listening to the needs of technicians and adapting to change, OFTEC will remain at the forefront of the off gas grid heating sector for years to come.

Swindon based installer Mark Sellwood, of M Sellwood Plumbing and Heating, was named winner of the Greenstar oil-fired boiler installation category at this year's annual Environment 2020 Awards, which aim to promote the use of sustainable heating and hot water solutions.



## Redesigning with **efficiency in mind**

After the decision was made to convert a former mill house into a family home, a new heating system needed to be installed. Mark's decision to fit energy efficient products in the home led him to pick up the installer award at this year's ceremony.

The property was previously powered by an oil boiler located internally with a conventional flue system that had reached the end of its operational life and was therefore in need of replacement. Mark opted to install an external Greenstar Camray oil-fired boiler\* as it was a more effective way of delivering the efficiency levels for years to come.

Speaking of the installation Mark commented: "The homeowner contacted me directly when they sought a new heating system, after consideration of their requirements and the reliability they needed, the Greenstar Camray was an easy recommendation for me to make. The homeowner is very pleased with the installation and has been surprised by the saving they have made in oil usage since having the A-rated boiler fitted."

The Environment E2020 Awards initiative is an annual competition which recognises the installers and specifiers who take an environmentally responsible approach to their work.

With eight categories in place, there is plenty of opportunity for you to enter an installation which demonstrates the excellent use of a wide range of technologies which enhance efficiency levels.

**For more information on our Environment 2020 Awards, and to download an entry form, visit [www.worcester-bosch.co.uk](http://www.worcester-bosch.co.uk)**

*\*Since time of writing this product has been discontinued and replaced with the Greenstar Danesmoor.*

# £100

## Greenstore Cylinder Cash Back\*

With any Greenstore unvented cylinder purchased between 1st January and 30th June 2015\*.

### PLUS the chance to WIN a Silverstone Challenge Day\*

Every valid claim form received in each month of the promotion will also qualify for entry into a fantastic **Silverstone Challenge Day FREE prize draw.**

Find out more in the next edition of Installer's Choice.



 **WORCESTER**  
Bosch Group

\*Terms and conditions apply.

## TRAINING



## Introducing **OFTEC 50**

Maintaining our commitment to the market for off mains gas heating and hot water solutions, we have recently launched a brand new training course to our portfolio, in association with OFTEC. The brand new course has been specifically designed to provide those of you with little or no experience with oil, with a first step towards OFTEC qualification.

OFTEC 50 is an entry level certificate which has been designed to give you an introduction to oil-fired systems and installations. Completion of the modules will enable you to be placed within a suitable category in order to then undertake the OFTEC 101, 105E and 600A qualifications.

Should you wish to take a place on the 5 day course, you need to hold a valid qualification relevant to the heating industry, such as Gas Safe, G3 Hot water systems, NVQ Level 3 or similar, or a minimum of two years' experience in the industry.

By giving you the opportunity to familiarise yourself with a wide variety of different processes from specification through to maintenance, you will also benefit from being able to work with our Greenstar Heatslave and Danesmoor oil-fired boilers. Each boiler was enhanced last year with a host of installer-friendly features, making them the ideal products to use as you get to grips with oil-fired heating.

We are offering this course at the special introductory price of £200. Not only that, any candidate who has undertaken an OFTEC 50 with us, would be eligible for £150 discount off an OFTEC 105e / 101 / 600a 4 day training and assessment course!

The course covers the following areas:

### Specification and Installation

- Health and Safety
- Oil Boiler Installation
- Oil Tank
- Oil Supply
- Pressure Jet Burners

### Commissioning, Servicing and Maintenance

- Servicing
- Commissioning
- Combustion
- Oil Tank
- Oil Supply

### Fault Finding

- Sequence of Operation
- Component Testing

Upon completion of the course, each delegate is given a certificate of attendance to demonstrate a foundation level of knowledge. To find out more or to book a place on the OFTEC 50 course, visit [www.worcester-bosch.co.uk/training](http://www.worcester-bosch.co.uk/training) or call our Training Hotline on 0330 1230166.





## Technical Q&A

Ewan Sutherland and the team of technical service engineers answer some of the most common questions that they receive from you at this time of the year.

**Q. My customer wants to use the weather compensation function on their Wave control. Can you explain how it works and what is the benefit?**

**A.** Weather compensation is achieved by the controller monitoring the outside air temperature by an online weather station which references the homeowners postcode. Using this weather information the controller determines the flow temperature required to achieve the desired comfort level within the property.

Because of this, the heating system can operate at a lower flow temperature maintaining a constant temperature inside the property irrespective of the outside temperature; subsequently the boiler will produce more condensate during operation.

**Q. Can I use the Wave with another manufacturers boilers?**

**A.** The Wave is only compatible with Energy Management System (EMS) enabled Worcester boilers. The compatible boilers are listed on our website.

**Q. How do I connect the Wave to a Worcester boiler?**

**A.** The Wave must be connected directly to the low voltage BUS connection on the boiler PCB which is referenced as EMS or BB terminals depending on the boiler type. Utilise the EMS (BUS) connection on the boiler PCB if installing a CDi Compact shown in Fig.1 or the BB (BUS) connection on the boiler PCB for all other appliances shown in Fig.2.

See the installation instructions for the boiler for more information on the BUS connection.

Under no circumstances must the Wave be connected to any 230 volts supply.

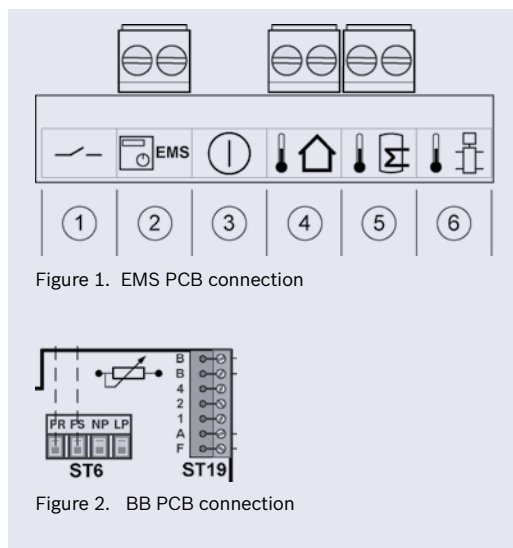

Figure 1. EMS PCB connection

Figure 2. BB PCB connection

**Q. My customer has downloaded the Wave app onto their tablet and discovered the home presence detection will not activate. Is there a reason for this and how can they activate home presence detection?**

**A.** Home detection can only be activated when installed onto a mobile device. If the app is first installed onto a tablet and home presence detection cannot be enabled. In this situation follow the procedure below:-

- Remove the App from all devices.
- Reinstall the App first onto the mobile device.
- Follow the registration and pairing procedure.
- Activate the home presence detection.
- Reinstall App onto any other devices.

**For further technical information on the Wave, visit [www.worcester-bosch.co.uk](http://www.worcester-bosch.co.uk). Alternatively, you can access videos, hints and tips via the Wave App or our YouTube channel.**

## WIN A NEW GREENSTAR COMFORT CONTROL

To celebrate the launch of our brand new range of controls, we are giving you the chance to be amongst the first to get your hands on a Greenstar Comfort I RF twin channel programmer.



Intelligent and simple to use, the new Comfort controls, are quick and easy to install, and are backed up by the quality and reliability you can expect from the Worcester brand. The intuitive menu control and ease of installation make our new Greenstar Comfort controls simple for you to fit and for your customers to use.

To be in with a chance of winning one of 20 Greenstar Comfort I RF twin channel programmer simply answer the question below correctly;

**What percentage uplift in efficiency will the room temperature sensing Comfort controls offer under the forthcoming ErP Directive?**

- a) 2%
- b) 3%
- c) 4%

Your Answer:

Send your entry back to our editorial office:  
**Installer's Choice December Competition,**  
 Willoughby PR, 43 Calthorpe Road, Edgbaston,  
 Birmingham, B15 1TS.

**For terms and conditions please visit our website: [www.worcester-bosch.co.uk/installer/literature/worcesters-magazine-the-installers-choice](http://www.worcester-bosch.co.uk/installer/literature/worcesters-magazine-the-installers-choice)**

Name:

Business Name:

Business Address:

Daytime Telephone Number:

Email:



## Keep in touch with our technical team

To offer you constant support throughout the peak heating season we have a team of technical experts who are on hand to offer assistance on any queries relating to our complete range of domestic heating solutions.

Our dedicated technical team consists of over 40 advisors who take in excess of 450,000 calls annually. It is our aim to answer all your queries as quickly as possible, therefore our average response time for incoming calls in our technical department is just six seconds.

The quality of our technical team is second to none and in 2014 they were named the Best Technical Support Team at the OFTEC awards.

Each member of the technical support team participates in a comprehensive training programme, which includes ongoing practical installation, commissioning and servicing of live boilers, heat pumps and solar systems, to ensure they can offer you the best advice possible when you get in touch.

The technical support department are able to handle incoming queries via phone, email, post, and nowadays by FaceTime and Skype.

### Standard opening hours:

Monday to Friday 7.00am - 8.00pm  
Saturday 8.30am - 4.00pm

### Christmas opening hours:

Xmas day closed, 8-4.30 Boxing day & New years day



## HOW TO GET IN TOUCH

Technical enquiry line:  
**0330 123 3366**

Renewable technologies enquiry line (for enquiries about solar water heating and heat pumps):  
**0330 123 9229**

If you are wishing to contact the Engineering Services department using FaceTime® you can do so via [technical.enquiries@uk.bosch.com](mailto:technical.enquiries@uk.bosch.com)

Alternatively, Skype™ users can get in touch with Worcester via [worcestertechnical](https://www.skype.com/uk/worcestertechnical).

The only boiler manufacturer to be awarded **Which? Best Buy** for 2014/2015\*



For the second year running, we are the **most reliable boiler brand and scored highest for customer satisfaction** across our entire gas boiler range.

Visit [www.worcester-bosch.co.uk](http://www.worcester-bosch.co.uk) to find out more.

**WORCESTER**  
Bosch Group

\*Which? annual boiler report September 2014.