

Installation and Maintenance Instructions

Sealed and open vented heating system filter

Greenstar System Filter Mini

Water treatment product

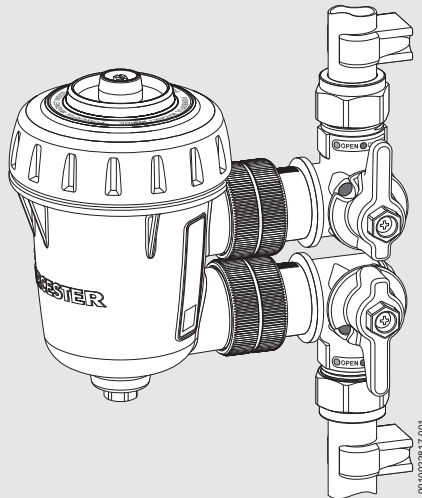

Table of contents

1 Explanation of symbols and safety instructions2
 1.1 Explanation of symbols2

2 General safety instructions3

3 Product Information3
 3.1 Scope of delivery4
 3.2 General information4
 3.3 System filter - pressure drop4
 3.4 Dimensions4
 3.5 System filter function5

4 Pre-installation5
 4.1 Protecting the heating system5
 4.2 Installation location within system pipe work6

5 Installation7
 5.1 Pipe work preparation7
 5.2 Fitting the filter8

6 Commissioning8
 6.1 System inhibitor from bottle8
 6.2 System inhibitor from canister9
 6.3 Final actions:10

7 Environmental protection and disposal 10

8 Inspection and maintenance 11
 8.1 Inspection and cleaning 11
 8.2 Recommissioning 12
 8.2.1 System inhibitor from bottle 12
 8.2.2 System inhibitor from canister 13

9 Spare Parts 13

10 Guarantee 13

11 Technical Specifications/Logs 14
 11.1 Service record 14

1 Explanation of symbols and safety instructions

1.1 Explanation of symbols

Warnings

In warnings, signal words at the beginning of a warning are used to indicate the type and seriousness of the ensuing risk if measures for minimising danger are not taken.

The following signal words are defined and can be used in this document:

 **DANGER**
DANGER indicates that severe or life-threatening personal injury will occur.

 **WARNING**
WARNING indicates that severe to life-threatening personal injury may occur.

 **CAUTION**
CAUTION indicates that minor to medium personal injury may occur.

NOTICE
NOTICE indicates that material damage may occur.

Important information

 The info symbol indicates important information where there is no risk to people or property.

Additional symbols

Symbol	Meaning
▶	a step in an action sequence
→	a reference to a related part in the document
•	a list entry
–	a list entry (second level)

Table 1

2 General safety instructions

Powerful magnetic field



Magnetic hazard to equipment or tools!

- ▶ This product contains a strong magnet.

Additional safety instructions

Please read these instructions in conjunction with the appliance Installation and Maintenance Instructions carefully before starting installation.

- ▶ Observe all the safety precautions described in the Installation and Maintenance Instructions for the appliance.

Fitting and modification

The unit must not be fitted in any way other than described in the Installation Instructions and any misuse or unauthorised modifications to the unit or associated components and systems could invalidate the guarantee. The manufacturer accepts no liability arising from any such actions. This does not affect your statutory rights.

3 Product Information

The following instructions are designed to assist engineers in the safe and effective installation and servicing of the Greenstar System Filter Mini and should be followed at all times.

Any queries arising from either the installation or servicing should be directed to Worcester, Bosch Group Technical Support.

For sealed and open vent central heating systems with 22mm pipework.



The Greenstar System Filter Mini should only be installed by a competent person. If in any doubt, consult a qualified heating engineer.

Health and safety

The appliance contains no substances that contravene the COSHH Regulations (Control of Substances Hazardous to Health regulations 1988).

3.1 Scope of delivery

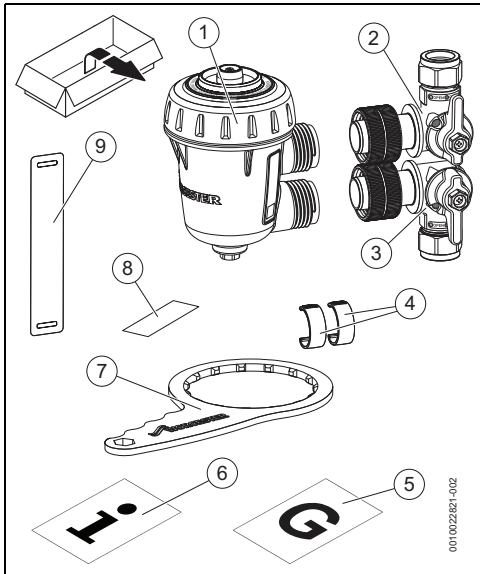

Fig. 1 Standard package

- [1] Greenstar System Filter Mini
- [2] Isolating valve - A (22mm compression fitting)
- [3] Isolating valve - B (22mm compression fitting)
- [4] Valve "C" clips
- [5] Guarantee card
- [6] Installation and Maintenance Instructions
- [7] Lid servicing tool
- [8] Label "System filter fitted"
- [9] Pipe cutting template

3.2 General information

The Greenstar System Filter Mini incorporates a powerful internal magnet with a cyclonic trap that removes both magnetic and non-magnetic particles.

The system filter can be installed on the heating systems return pipe providing there is sufficient residual pump head to overcome the hydraulic resistance at higher flow rates.

The system should be flushed and a suitable inhibitor added in accordance with BS7593 before installing the Greenstar System Filter Mini. Failure to comply with the guidance will limit the effectiveness of the Greenstar System Filter Mini in protecting your boiler and central heating system.

3.3 System filter - pressure drop

This graph shows the pressure drop through the filter in relation to flow rate in the system.

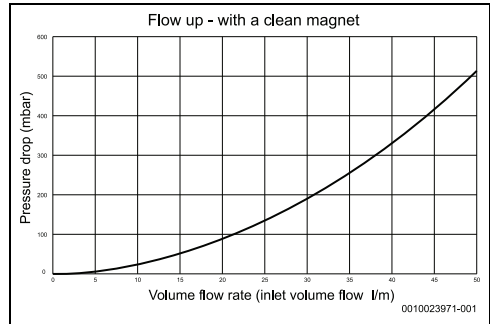

Fig. 2 Pressure drop graph

3.4 Dimensions

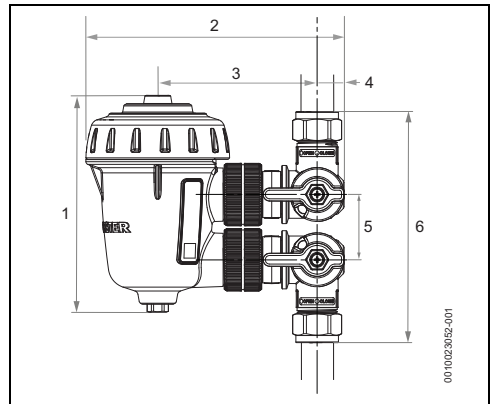

Fig. 3 Dimensions - Mini system filter

- [1] 155mm
- [2] 182mm
- [3] 112mm
- [4] 19mm
- [5] 46mm
- [6] 163mm

3.5 System filter function

The system filter is bi-directional, this means that the central heating water can flow either way through the filter, from top to bottom or from bottom to top.

The central heating system water is circulated through the filter to remove the black iron oxide sludge and other non-magnetic debris.

The system water is slowed down as it circulates around the filter where a powerful magnet captures the potentially damaging iron oxide sludge, preventing it from being circulated within the system thereby protecting the heat exchanger, pump and valves. The other non-magnetic debris is captured within the traps at the top and bottom of the filter.

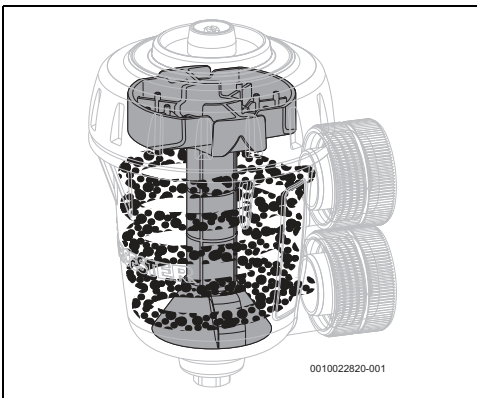

Fig. 4 System filter

4 Pre-installation

4.1 Protecting the heating system

Unnecessary breakdowns

A contaminated central heating system can cause pumps, heat exchangers and valves to block.

The contamination can also cause radiator cold spots that will reduce the effectivity of that radiator and even cause the radiator to corrode from the inside, resulting in leaks.

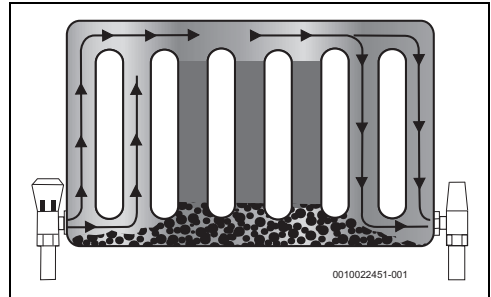

Fig. 5 Radiator contamination

Increased fuel usage and bills

Dirty water also creates a build up of sludge that coats the inside of radiators and the boiler heat exchanger.

This sludge creates a barrier inside the radiators and effectively reduces heat from that radiator into the room. This results in your heating system working harder to overcome the layers of dirt in the system to achieve your desired room temperature. The heating system will use more fuel in an effort to reach your desired room temperature, leading to higher heating bills.

Your options

Every system is different and advice should be taken from your reputable heating engineer to comply with BS 7593 (Code of practice for treatment of water in central heating systems).

Best practice would be to have your system drained, refilled with water and a flushing chemical.

This would then be drained and flushed with clean water until the water runs completely clear.

Where the filter is installed on an existing system that shows signs of magnetite contamination a chemical gravity flush of the system is required or for best practice a power flush or alternatively a MagnaCleanse® flush is undertaken prior to installation.

To ensure that dirt does not build up again, a system filter should be fitted and a chemical inhibitor added. The system filter should be cleaned each year during the annual boiler service.

4.2 Installation location within system pipe work

The filter can be installed anywhere on the primary pipe work, except between the boiler and the feed and expansion pipes on an open vent system. To maximise the effectiveness it should be placed on the primary heating return before the boiler and after the last radiator on a vertical run of pipe work. In determining a suitable location for installation, it is important to ensure you allow adequate access for servicing.

Open vented system

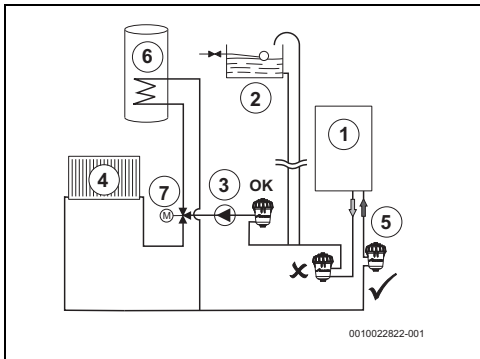

Fig. 6

- [1] Appliance
- [2] Open vent tank
- [3] Pump
- [4] Radiator
- [5] System filter
- [6] Cylinder
- [7] Diverter Valve
- [✓] Optimum location
- [OK] Suitable location
- [x] Unsuitable location

Sealed system



When a System appliance has a diverter valve fitted, the System filter should be on the heating return not cylinder return

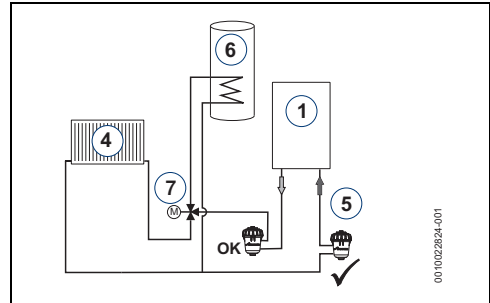

Fig. 7

- [1] Appliance
- [4] Radiator
- [5] System filter
- [6] Cylinder
- [7] Diverter Valve
- [✓] Optimum location
- [OK] Suitable location

Combi - sealed system

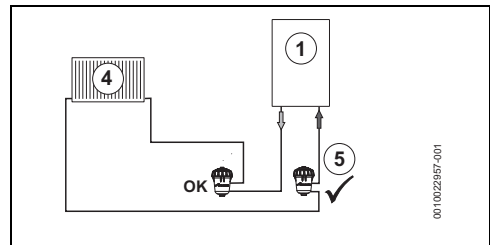

Fig. 8

- [1] Appliance
- [4] Radiator
- [5] System filter
- [✓] Optimum location
- [OK] Suitable location

5 Installation

5.1 Pipe work preparation



CAUTION

Risk of injury or damage to property

- ▶ Before commencing any work, turn off all supplies to the appliance and drain the heating system.
- ▶ Drain the heating system.
- ▶ Choose a suitable location, preferably on the return pipe to the appliance.
- ▶ Use the template [1] to mark out a section of pipe, cut and remove that section:
 - Dimension = 112mm for the Greenstar System Filter Mini.
- ▶ Ensure that the pipes are adequately supported above and below the cut sections on the wall.

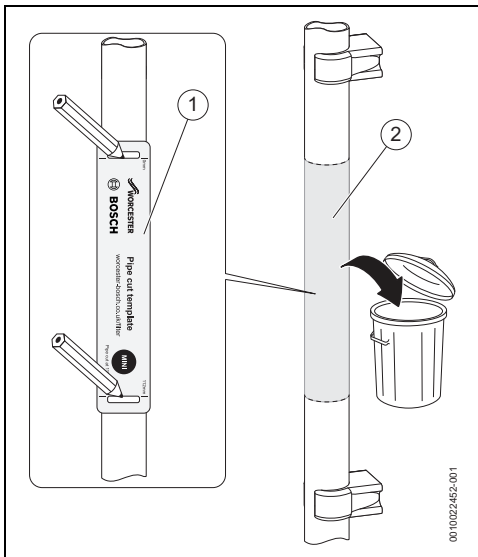

Fig. 9 Pipe work measuring and cutting

- ▶ Deburr the cut ends of the pipe and fit the nuts/olives over the pipe ends.
- ▶ Loosely fit the bottom isolating valve [B].
 - The bottom valve has a stop point inside to allow the pipe to fit at the correct height on the pipe.
- ▶ Loosely fit the top isolating valve [A].
 - The top valve has a no stop point inside to allow adjustment in height on the pipe to aid fitting in installations with limited space.

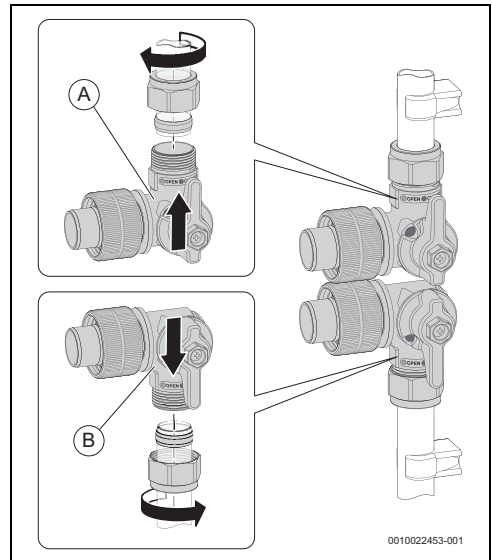

Fig. 10 Pipe connection fittings

5.2 Fitting the filter



Isolating valves shown closed in figure 11.

- ▶ Align the system filter connections [1] to the isolation valve connections [2] and fit the system filter.
- ▶ Tighten by hand the knurled nuts to secure the system filter.
 - Do not over tighten the connections.
- ▶ Tighten the isolating valve compression fittings [3] once the system filter has been fitted.
 - Do not over tighten the isolating valve compression fittings [3].

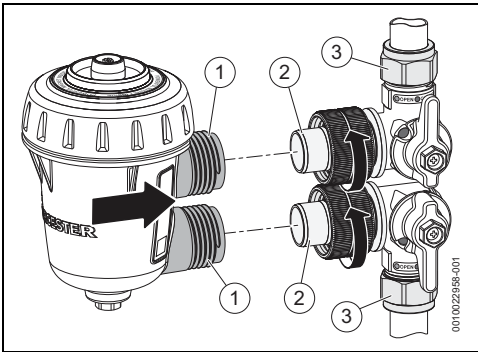

Fig. 11 Fit the system filter

- ▶ Fit “C” clips [3] between the valve body and the knurled nuts to ensure the knurled nuts are tight.

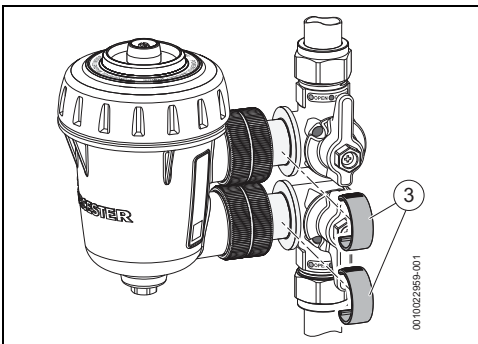

Fig. 12 Fit the C clips

6 Commissioning

System protection

Chemicals can be added by either:

- by removing the lid and pouring from a bottle.
- or–
- by injection from a canister, with the removal of the air vent and inserting the nozzle of the canister.



The following commissioning actions assume the heating system is fully drained.

6.1 System inhibitor from bottle

- ▶ Ensure that the isolation valves [2] are in the open position as indicated by the green marker on the valve.
- ▶ Loosen the lid assembly using lid servicing tool [1] provided and remove the assembly and sleeve [3].

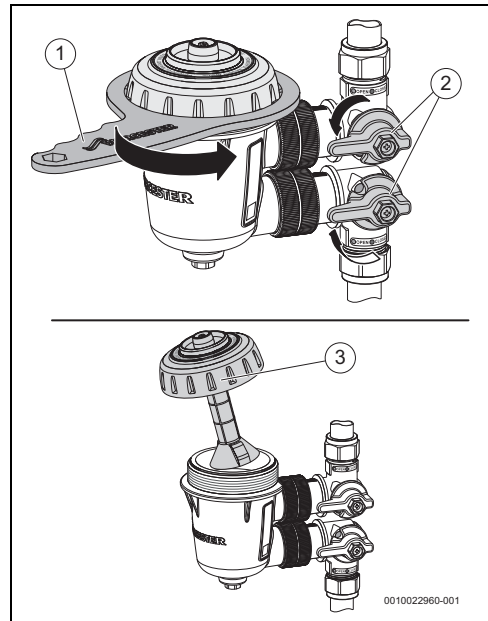

Fig. 13 Removing the lid

- ▶ Add a recommended system inhibitor.
- ▶ Replace the lid assembly and sleeve and secure using the lid servicing tool provided. There are stops to indicate the lid is secure.

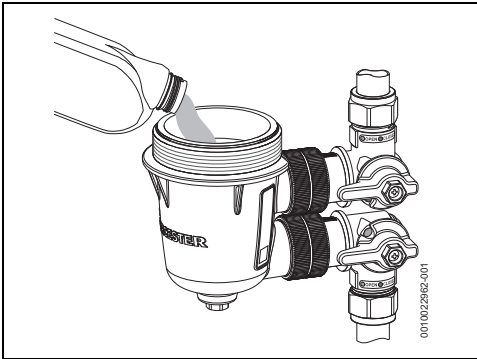

Fig. 14 Adding inhibitor

- ▶ Refill the system.
- ▶ Using a radiator key [5], open the vent via the bleed screw [4] to allow the air in the system to escape.
- ▶ Close the vent via bleed screw [4] when water runs out.

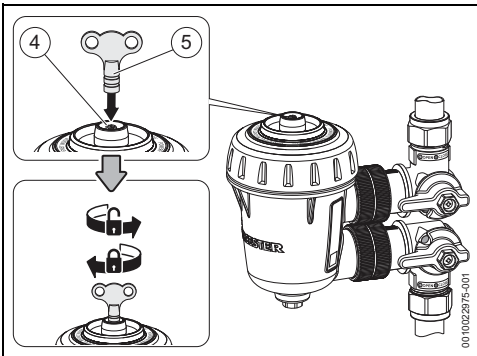

Fig. 15 Venting the filter

6.2 System inhibitor from canister



The adaptor on market leading chemical additives, either liquid or concentrate form, will fit into the vent once the bleed screw has been removed.

- ▶ Ensure that the isolation valves [3] are in the open position as indicated by the green marker on the valve.
- ▶ Remove the vent bleed screw [1] using a radiator key [2].

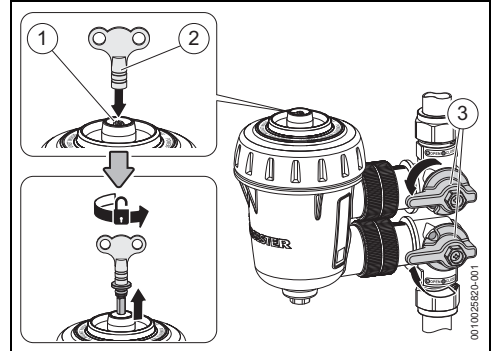

Fig. 16 Removing the vent bleed screw

- ▶ Insert the chemical adaptor or tube into the vent and feed in the chemical.

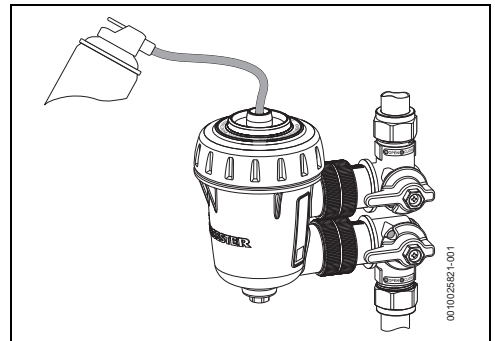

Fig. 17 Adding inhibitor

- ▶ Using a radiator key [2], replace the vent bleed screw [1].

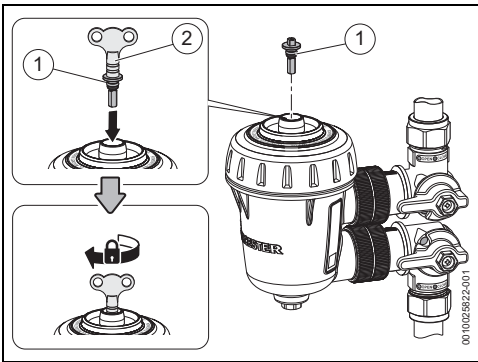

Fig. 18 Replacing the vent bleed screw

- ▶ Refill the system.

6.3 Final actions:

- ▶ Run the central heating system and check for leaks on the System Filter.
- ▶ Clean the System Filter case, ensuring no residue from the installation and commissioning is left behind on the filter or isolation valves.
- ▶ Attach the self-adhesive label stating “Your boiler and system are protected by a Greenstar System Filter Mini” that is supplied with the System Filter, to the boiler in a prominent position.
- ▶ Store the servicing tools and instruction manual away for future use.

7 Environmental protection and disposal

Environmental protection is a fundamental corporate strategy of the Bosch Group.

The quality of our products, their economy and environmental safety are all of equal importance to us and all environmental protection legislation and regulations are strictly observed. We use the best possible technology and materials for protecting the environment taking account of economic considerations.

Packaging

Where packaging is concerned, we participate in country-specific recycling processes that ensure optimum recycling. All of our packaging materials are environmentally compatible and can be recycled.

Used products

Used products contain valuable materials that can be recycled. The various assemblies can be easily dismantled. Synthetic materials can be recycled and are marked accordingly. Assemblies can therefore be sorted by composition and passed on for recycling or disposal.

8 Inspection and maintenance

8.1 Inspection and cleaning

NOTICE

Sludge disposal

Magnetite sludge can stain certain types of sinks or basins.

- ▶ Rinse the magnetite sludge into a stainless steel or plastic container.



Worcester, Bosch Group recommends for best practice that where any O ring seals are disturbed that these O ring seals are replaced.

- ▶ Turn both isolation valves [2] to the closed position as indicated by the red marker on the valve.
- ▶ Use a radiator key to open the vent bleed screw [1]
- ▶ Using the small hexagonal end of the lid servicing tool, open and remove the drain plug [3]; use a suitable container to collect any water and debris.
- ▶ Replace the drain plug [3] and secure, do not overtighten.

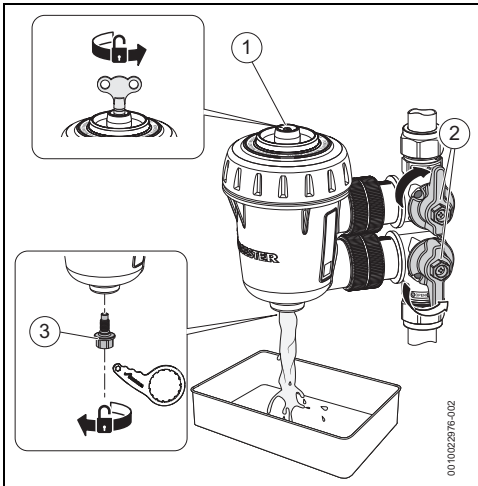

Fig. 19 Draining the filter

- ▶ Using the lid servicing tool [4], loosen the lid assembly.

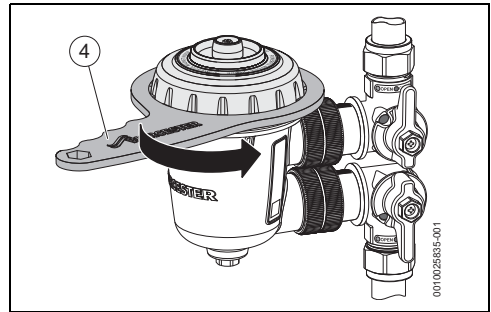

Fig. 20 Releasing the lid

- ▶ Remove the lid assembly and sleeve [5].
 - Using a cloth or rag to prevent any spillage as you move to stainless steel or plastic container.

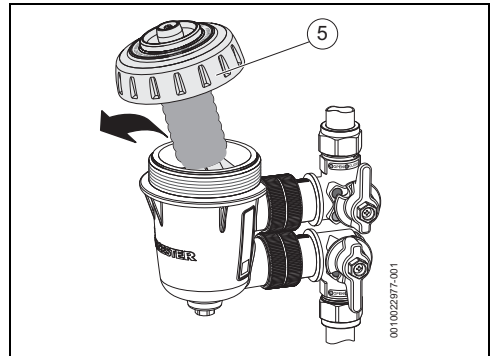

Fig. 21 Sludge removal

- ▶ Under running water slide the sleeve [6] off the magnet.
- ▶ Rinse the magnetite sludge off the sleeve [7].
- ▶ Rinse the end of the sleeve [8] to remove any non-magnetic debris.
- ▶ Rinse any non magnetic debris from inside the trap [9].

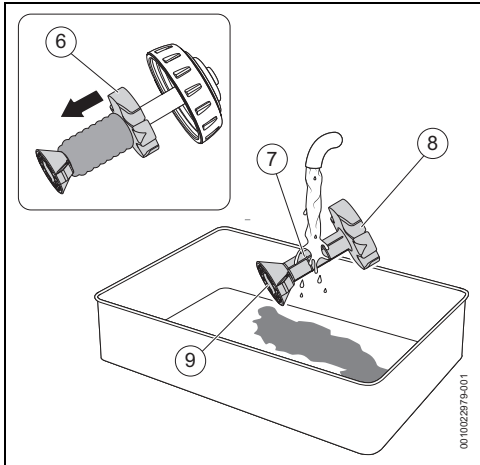

Fig. 22 Cleaning the sheath

8.2 Recommissioning



Recommissioning the system filter.

- ▶ **Full system drain down**
 - Follow the details given in the Commissioning section.
- ▶ **System filter drain down**
 - Use the following advice.

8.2.1 System inhibitor from bottle

- ▶ Top up the system with a recommended Inhibitor.
- ▶ Replace the sleeve back over the magnet.
- ▶ Replace the sleeve and lid assembly and tighten by hand.
- ▶ Secure the lid firmly, do not over tighten, using the lid servicing tool. There are stops to indicate the lid is secure.

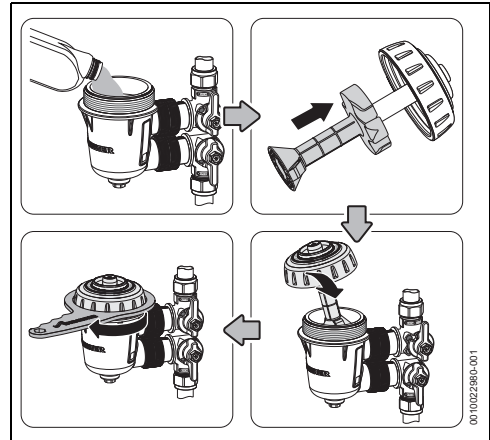

Fig. 1 Top up and refitting lid

- ▶ Turn both isolation valves [1] to the open position, as indicated by the green marker on the valve.
- ▶ Using a radiator key [3], open the vent via the bleed screw [2] to allow the air in the system to escape.
- ▶ Close the vent via bleed screw [2] when water runs out.

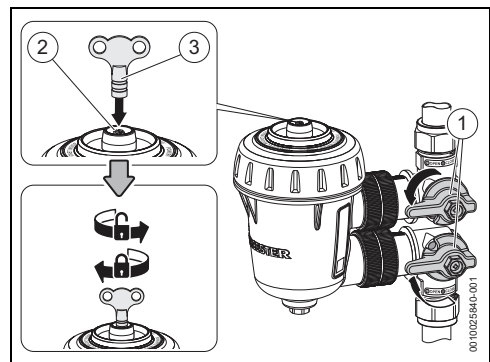

Fig. 2 Vent the filter

8.2.2 System inhibitor from canister

- ▶ Replace the sleeve back over the magnet.
- ▶ Replace the sleeve and lid assembly and tighten by hand.
- ▶ Secure the lid firmly, do not over tighten, using the lid servicing tool. There are stops to indicate the lid is secure.
- ▶ Remove the vent bleed screw using a radiator key.

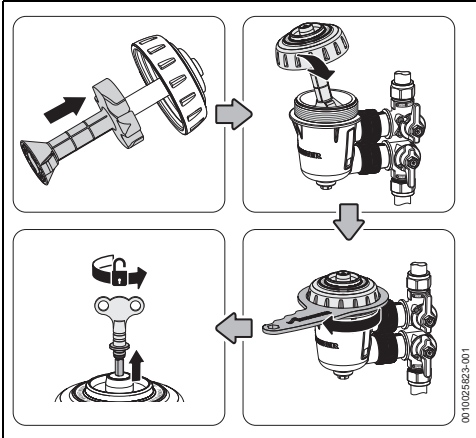

Fig. 1 Filter reassembly and vent bleed screw removal

- ▶ Insert the chemical adaptor or tube into the vent and feed in the chemical.
- ▶ Using a radiator key [2], replace the vent bleed screw [4].
- ▶ Turn both isolation valves [1] to the open position, as indicated by the green marker on the valve.

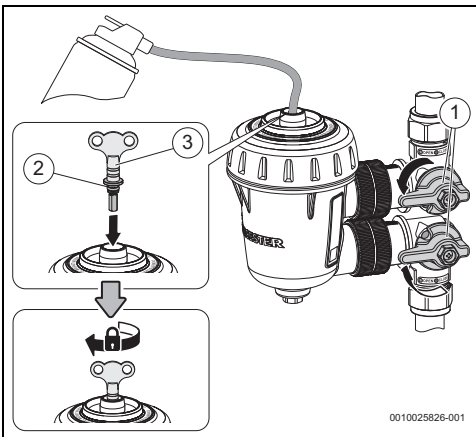

Fig. 2 Adding inhibitor and refitting vent bleed screw

9 Spare Parts

System filter - Spare parts

System filter - Mini

Part Number	Item
8 716 117 923	Lid tool
8 716 117 924	Valve tool
8 716 117 925	Air vent assembly
8 716 119 723	O ring pack
8 716 119 724	Sleeve assembly 22mm - short
8 716 119 725	Valve assembly A 22mm
8 716 119 726	Valve assembly B 22mm
8 716 119 727	Valve C clip 22mm
8 716 117 934	Drain plug assembly

Table 2

10 Guarantee

Guarantee registration

Your appliance/product carries a guarantee against faulty material or manufacture subject to Terms and Conditions.

To read the full Terms & Conditions please visit us on-line at www.worcester-bosch.co.uk/guarantee.

Your statutory rights are not affected by the manufacturer's guarantee.

11 Technical Specifications/Logs

11.1 Service record

It is recommended that your system filter is serviced annually at the same time as the main appliance service and that this Service Interval Record is completed as proof of the service.

Service Provider

Before completing the appropriate Service Record Below, please ensure you have carried out the service as described in the servicing section of the manual. Always use Worcester approved parts.

Service 1	Date:
Engineer Name:	
Company Name:	
Telephone No.	
Comments:	
Signature:	

Service 2	Date:
Engineer Name:	
Company Name:	
Telephone No.	
Comments:	
Signature:	

Service 3	Date:
Engineer Name:	
Company Name:	
Telephone No.	
Comments:	
Signature:	

Service 4	Date:
Engineer Name:	
Company Name:	
Telephone No.	
Comments:	
Signature:	

Service 5	Date:
Engineer Name:	
Company Name:	
Telephone No.	
Comments:	
Signature:	

Service 6	Date:
Engineer Name:	
Company Name:	
Telephone No.	
Comments:	
Signature:	

Service 7	Date:
Engineer Name:	
Company Name:	
Telephone No.	
Comments:	
Signature:	

Service 8	Date:
Engineer Name:	
Company Name:	
Telephone No.	
Comments:	
Signature:	

Service 9	Date:
Engineer Name:	
Company Name:	
Telephone No.	
Comments:	
Signature:	

Service 11	Date:
Engineer Name:	
Company Name:	
Telephone No.	
Comments:	
Signature:	

Service 13	Date:
Engineer Name:	
Company Name:	
Telephone No.	
Comments:	
Signature:	

Service 15	Date:
Engineer Name:	
Company Name:	
Telephone No.	
Comments:	
Signature:	

Service 10	Date:
Engineer Name:	
Company Name:	
Telephone No.	
Comments:	
Signature:	

Service 12	Date:
Engineer Name:	
Company Name:	
Telephone No.	
Comments:	
Signature:	

Service 14	Date:
Engineer Name:	
Company Name:	
Telephone No.	
Comments:	
Signature:	

TECHNICAL SUPPORT: 0330 123 3366
RENEWABLE SUPPORT: 0330 123 9229
CONTROLS AND CONNECTIVITY TEAM: 0330 123 3641
APPOINTMENTS: 0330 123 9339
SPARES: 0330 123 9779
LITERATURE: 0330 123 9119
TRAINING: 0330 123 0166
SALES: 0330 123 9669

Bosch Thermotechnology Ltd.
Cotswold Way, Warndon
Worcester WR4 9SW
United Kingdom
Tel. 0330 123 9559
worcester-bosch.co.uk

