

Compress 2000

System schematic and wiring diagrams

4kW to 16kW.





Compress 2000 4 - 16kW

Standard systems

CS2000 AWF R-S open circuit, DHW without buffer

CS2000 AWF R-S multi zone, DHW buffer & 3rd party controls

System Wiring

Pre-plumbed systems

CS2000 AWF R-S- Telford pre-plumbed-50L buffer 2z

CS2000 AWF R-S- Telford pre-plumbed-50L buffer (zone valves not included)

CS2000 AWF R-S- Telford pre-plumbed-50L buffer 1z

CS2000 AWF R-S- UK Cylinders pre-plumbed

CS2000 AWF R-S- UK Cylinders pre-plumbed 1z

CS2000 AWF R-S- UK Cylinders pre-plumbed, open circuit

Other systems

CS2000 AWF R-S- UK Cylinders horizontal with buffer

CS2000 AWF R-S- UK Cylinders horizontal open circuit















CS 2000 AWF R-S heating only without buffer

CS2000 AWF R-S heating only multi zone with buffer

Cascade systems

CS2000 AWF R-S - cascaded, DHW, 3rd party controls



Key	Description
	Antifreeze valve
	T1, T5, Tbt1 sensors
	Isolation valve
	Drain off valve
	Filling valve
	Three port valve
	Magnetic filter
	Non return valve
	3rd Party controls
	Pump
	Pressure gauge
	Strainer
	Immersion heater ³
	PRV ³

CS2000AWF 4 R-S to 6 R-S ensure a minimum system volume of 30L. CS2000AWF 8 R-S to 16 R-S ensure a minimum system volume of 40L

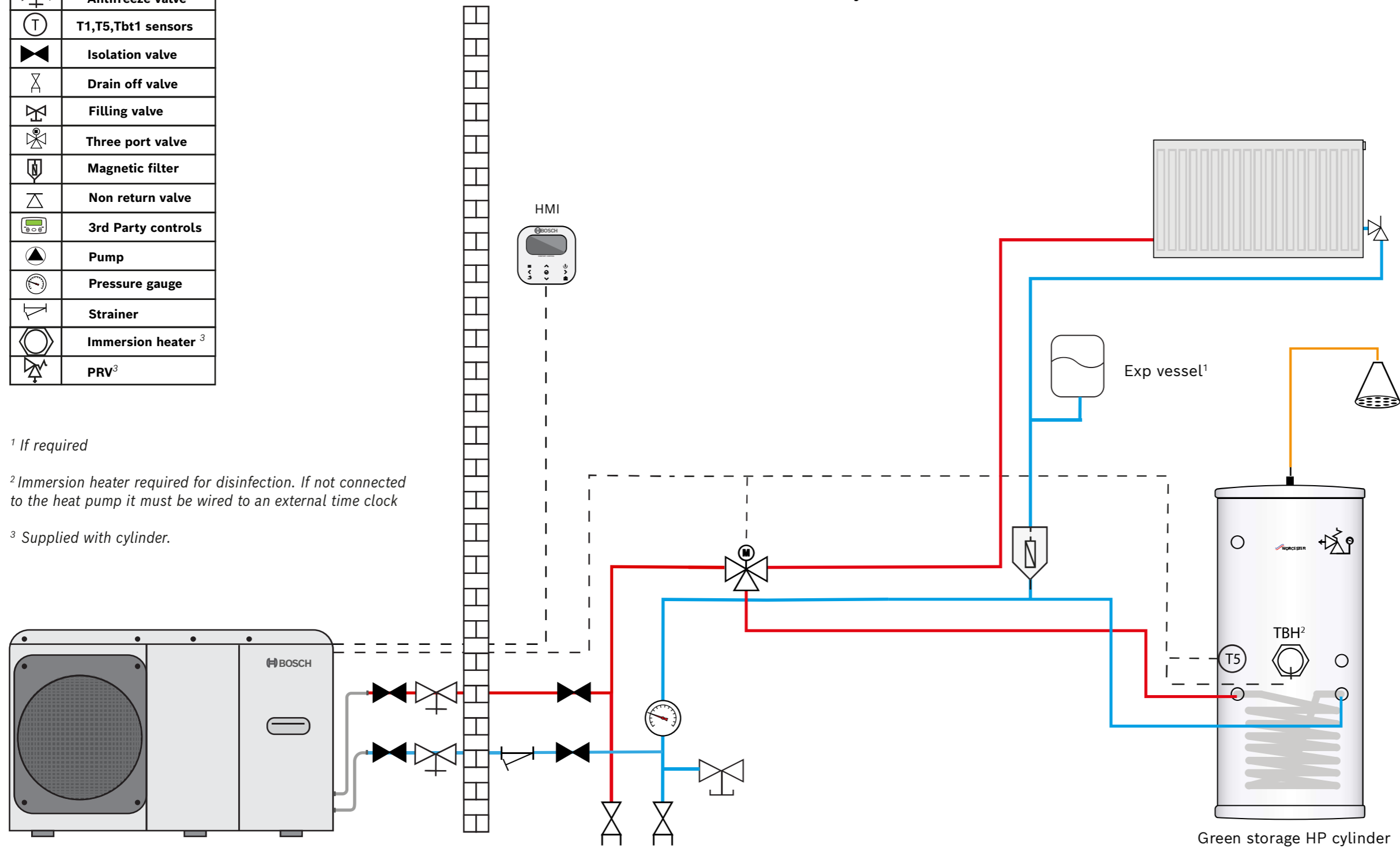

¹ If required

² Immersion heater required for disinfection. If not connected to the heat pump it must be wired to an external time clock

³ Supplied with cylinder.

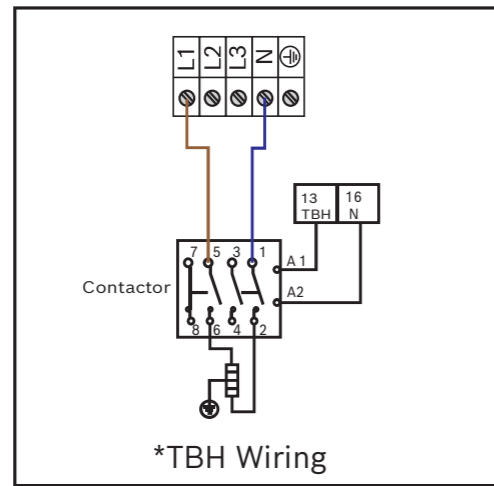
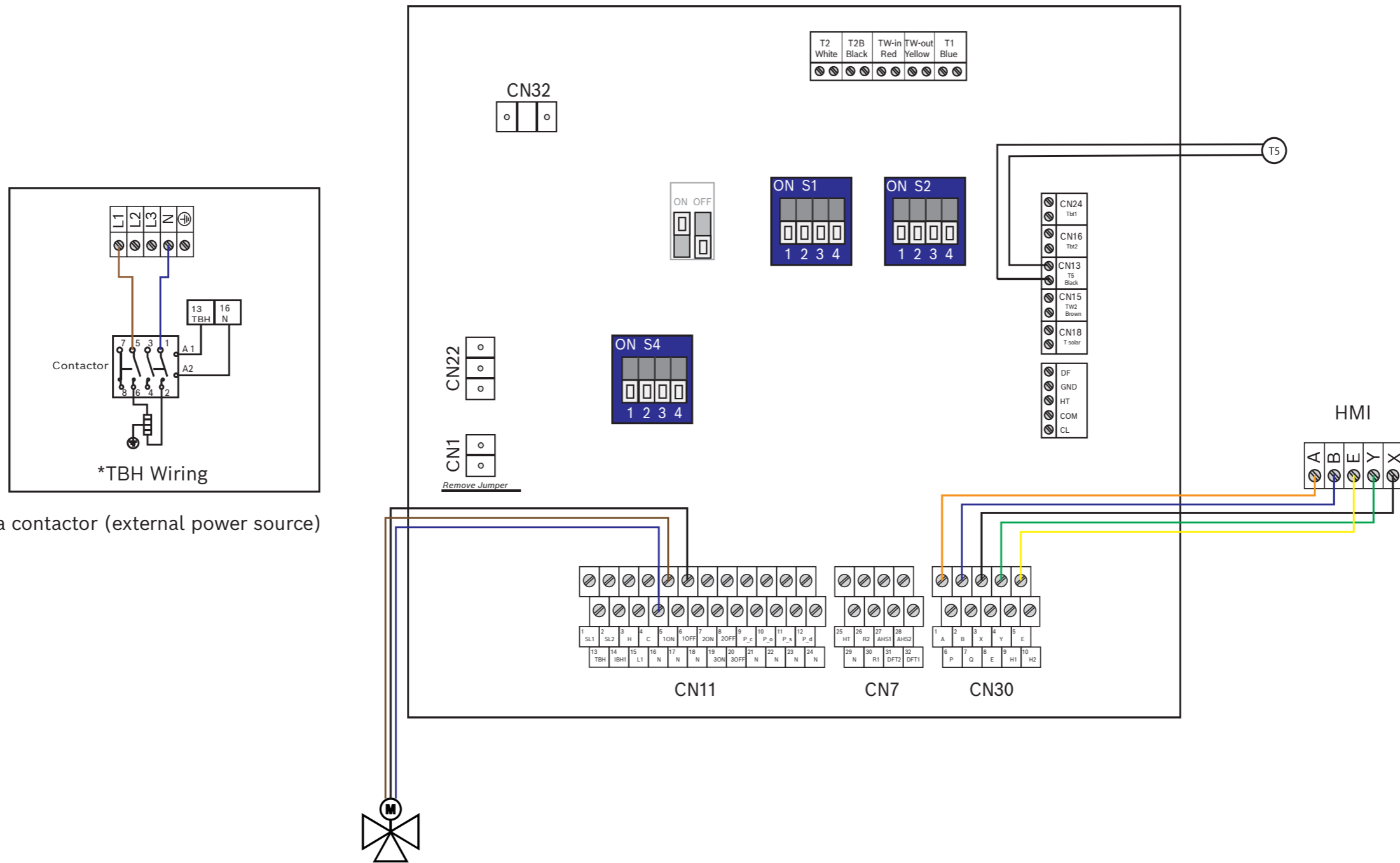

*Wired through a contactor (external power source)

If a third party diverter valve is used wiring and orientation may differ. Seek advice for compatible products

All electrical work should be carried out by a registered engineer. Wiring must comply with the latest IET wiring regulations.

Isolate the mains electricity supply before starting any work and observe all relevant safety precautions. Refer to all relevant product installation manuals for safety and installation instructions.

Whilst it is always our intention to fully assist, it is essential to recognise that all information given by the company is provided in good faith and based upon the information available. Connection labels may not match those of the products installed on site. We recommend that advice should always be checked with your installer, electrician or the manufacturer of the product in question. Consequently, the company cannot be held responsible for any liability relating to the use or repetition of such information or part thereof. In addition, whilst making every reasonable effort to monitor the performance and quality of our supply, installation and service network, we do not accept responsibility for the workmanship or operation of any third party company.



Key	Description
	Antifreeze valve
	T1, T5, Tbt1 sensors
	Isolation valve
	Drain off valve
	Filling valve
	Three port valve
	Magnetic filter
	Non return valve
	3rd party controls
	Pump
	Pressure gauge
	Strainer
	Two port valve ³
	Immersion heater ³
	PRV ³

CS2000AWF 4 R-S to 6 R-S ensure a minimum system volume of 30L. CS2000AWF 8 R-S to 16 R-S ensure a minimum system volume of 40L

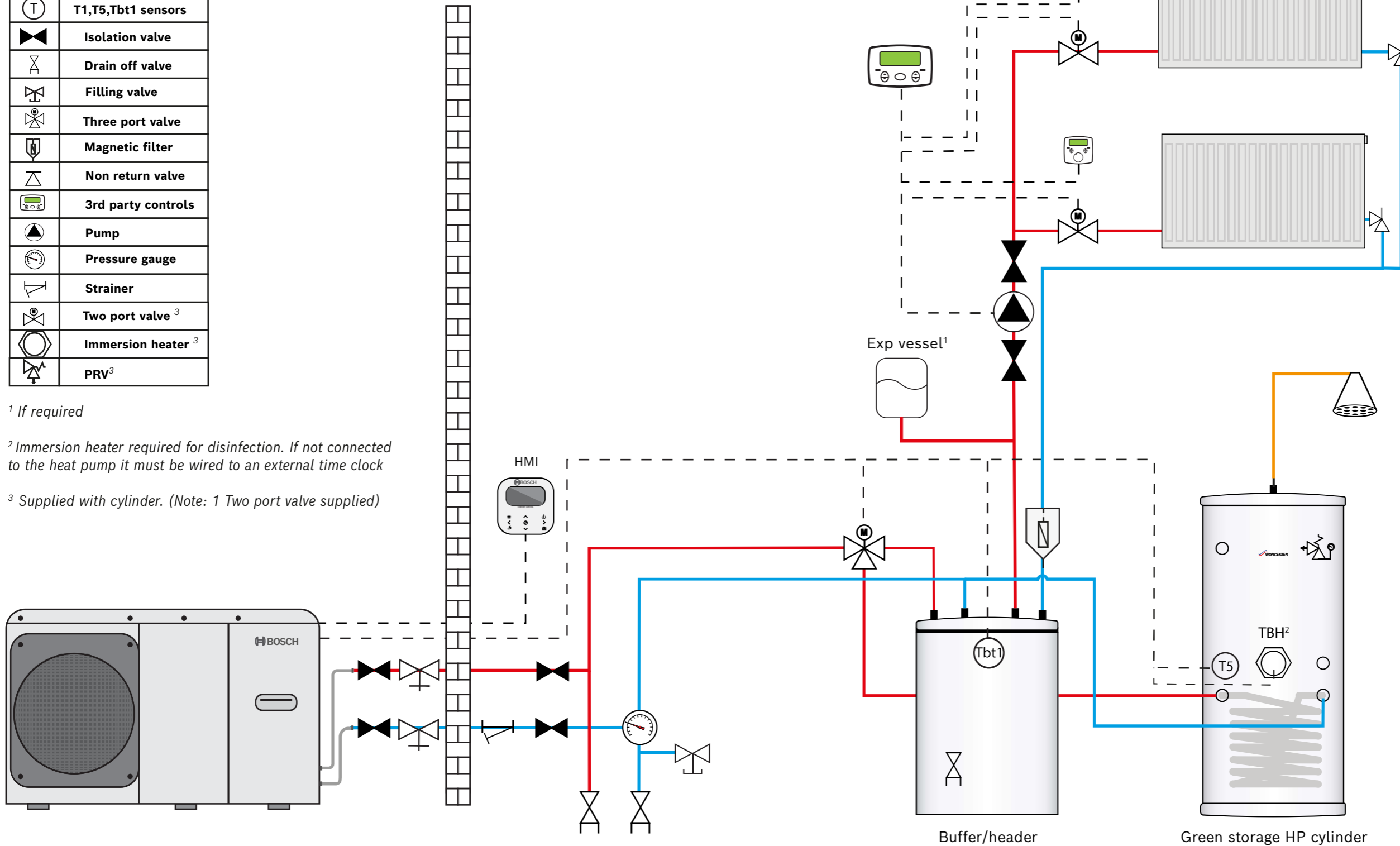

¹ If required

² Immersion heater required for disinfection. If not connected to the heat pump it must be wired to an external time clock

³ Supplied with cylinder. (Note: 1 Two port valve supplied)

All electrical work should be carried out by a registered engineer. Wiring must comply with the latest IET wiring regulations. Isolate the mains electricity supply before starting any work and observe all relevant safety precautions. Refer to all relevant product installation manuals for safety and installation instructions. Whilst it is always our intention to fully assist, it is essential to recognise that all information given by the company is provided in good faith and based upon the information available. Connection labels may not match those of the products installed on site. We recommend that advice should always be checked with your installer, electrician or the manufacturer of the product in question. Consequently, the company cannot be held responsible for any liability relating to the use or repetition of such information or part thereof. In addition, whilst making every reasonable effort to monitor the performance and quality of our supply, installation and service network, we do not accept responsibility for the workmanship or operation of any third party company.

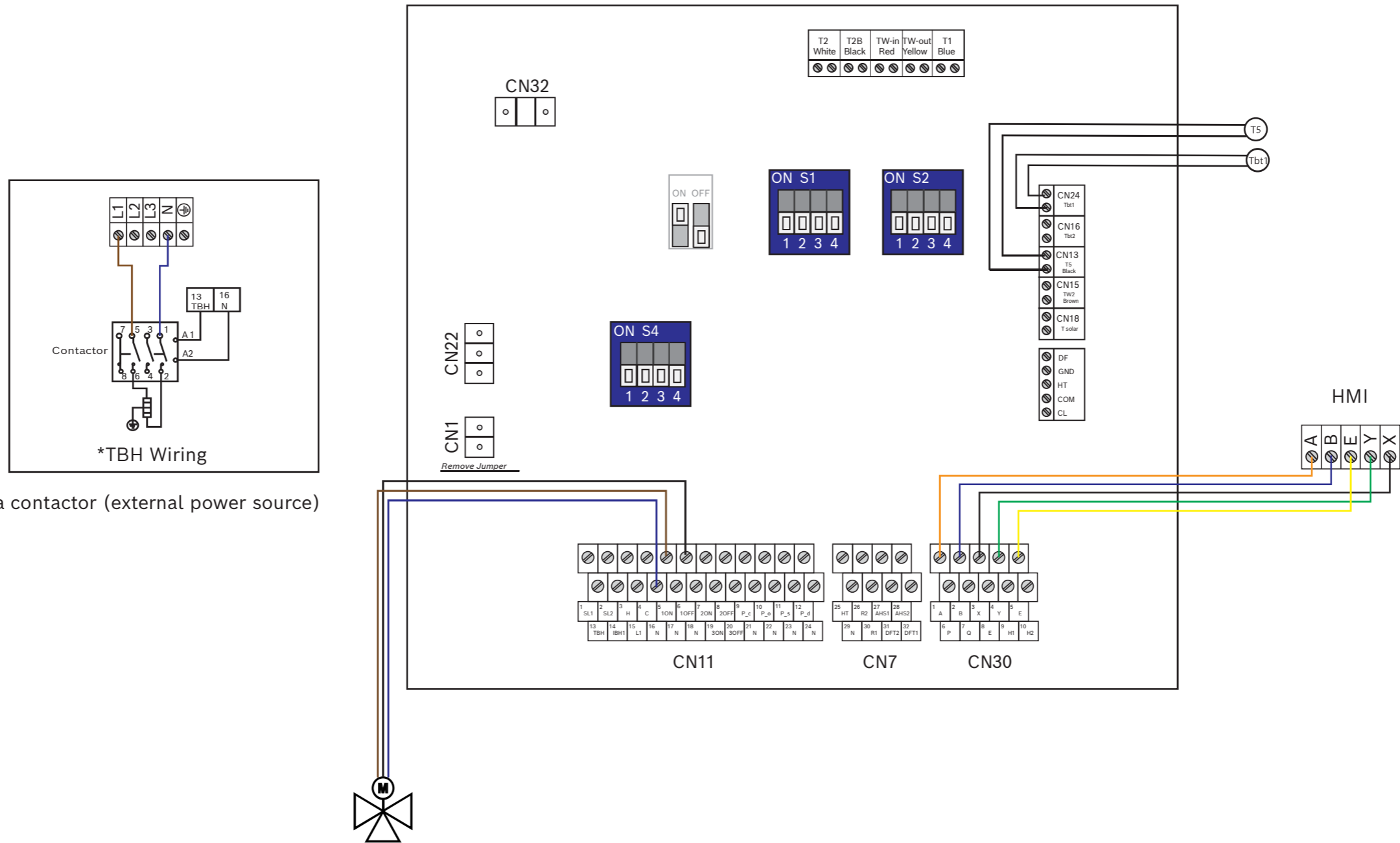

*Wired through a contactor (external power source)

If a third party diverter valve is used wiring and orientation may differ. Seek advice for compatible products

All electrical work should be carried out by a registered engineer. Wiring must comply with the latest IET wiring regulations.

Isolate the mains electricity supply before starting any work and observe all relevant safety precautions. Refer to all relevant product installation manuals for safety and installation instructions.

Whilst it is always our intention to fully assist, it is essential to recognise that all information given by the company is provided in good faith and based upon the information available. Connection labels may not match those of the products installed on site. We recommend that advice should always be checked with your installer, electrician or the manufacturer of the product in question. Consequently, the company cannot be held responsible for any liability relating to the use or repetition of such information or part thereof. In addition, whilst making every reasonable effort to monitor the performance and quality of our supply, installation and service network, we do not accept responsibility for the workmanship or operation of any third party company.

Key	Description
	Antifreeze valve
	T1, T5, Tbt1 sensors
	Isolation valve
	Drain off valve
	Filling valve ³
	Three port valve ³
	Magnetic filter ³
	Non return valve
	3rd party controls
	Pump ³
	Pressure gauge ³
	Strainer
	Two port valves ³
	Immersion heater ³
	PRV ³
	Air vent ³
	High limit stat ³

CS2000AWF 4 R-S to 6 R-S ensure a minimum system volume of 30L. CS2000AWF 8 R-S to 16 R-S ensure a minimum system volume of 40L

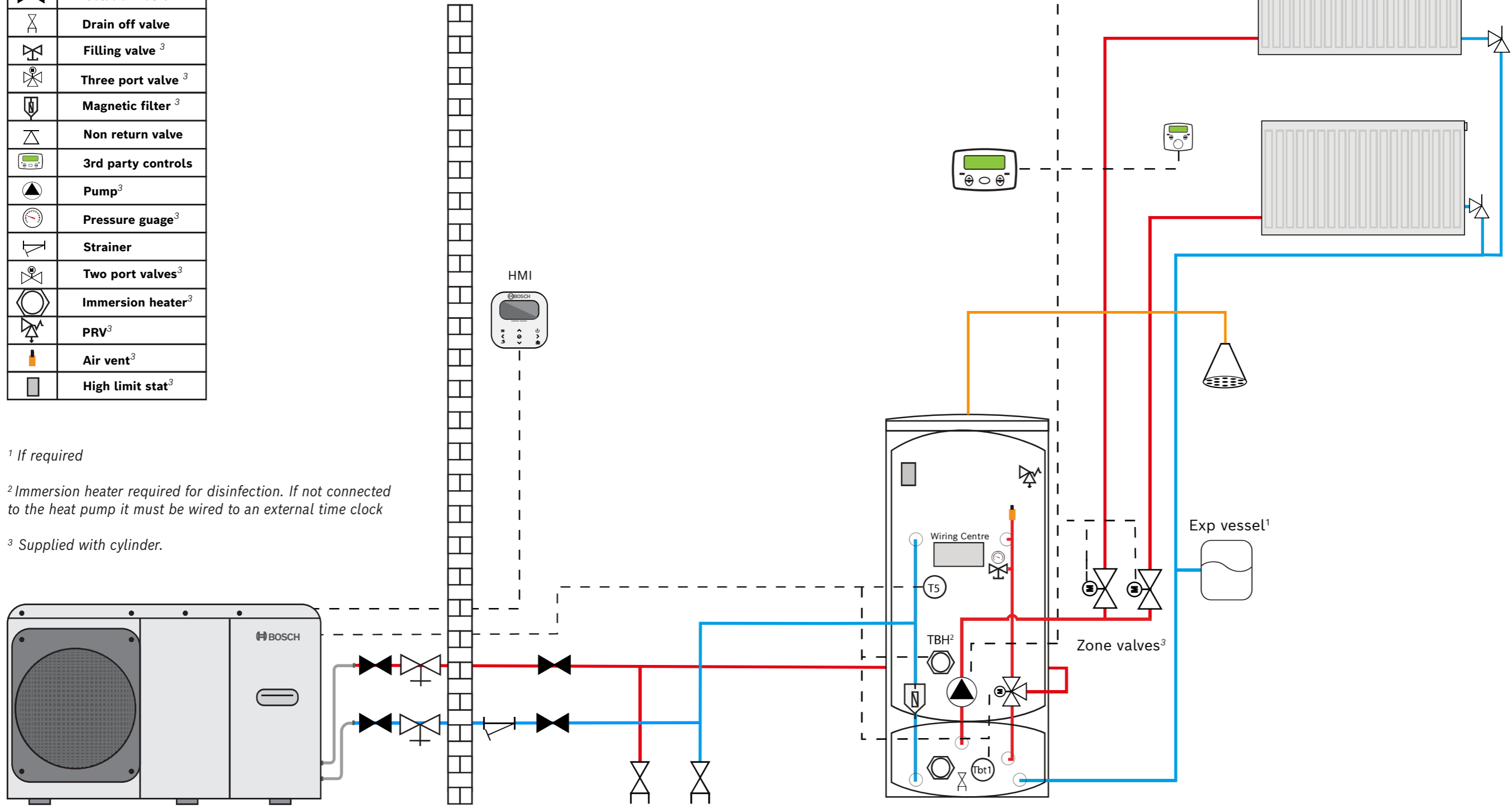

Telford Tempest HP/50L buffer pre-plumbed (2Z)

¹ If required

² Immersion heater required for disinfection. If not connected to the heat pump it must be wired to an external time clock

³ Supplied with cylinder.

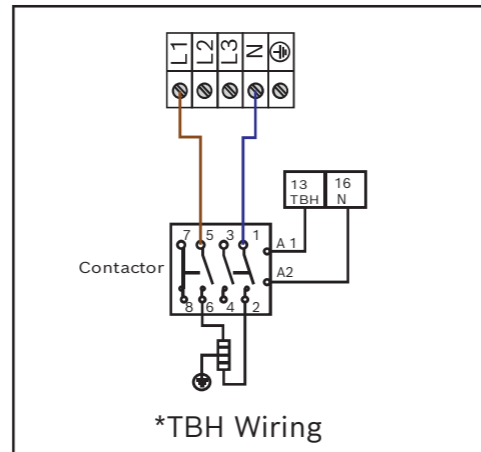
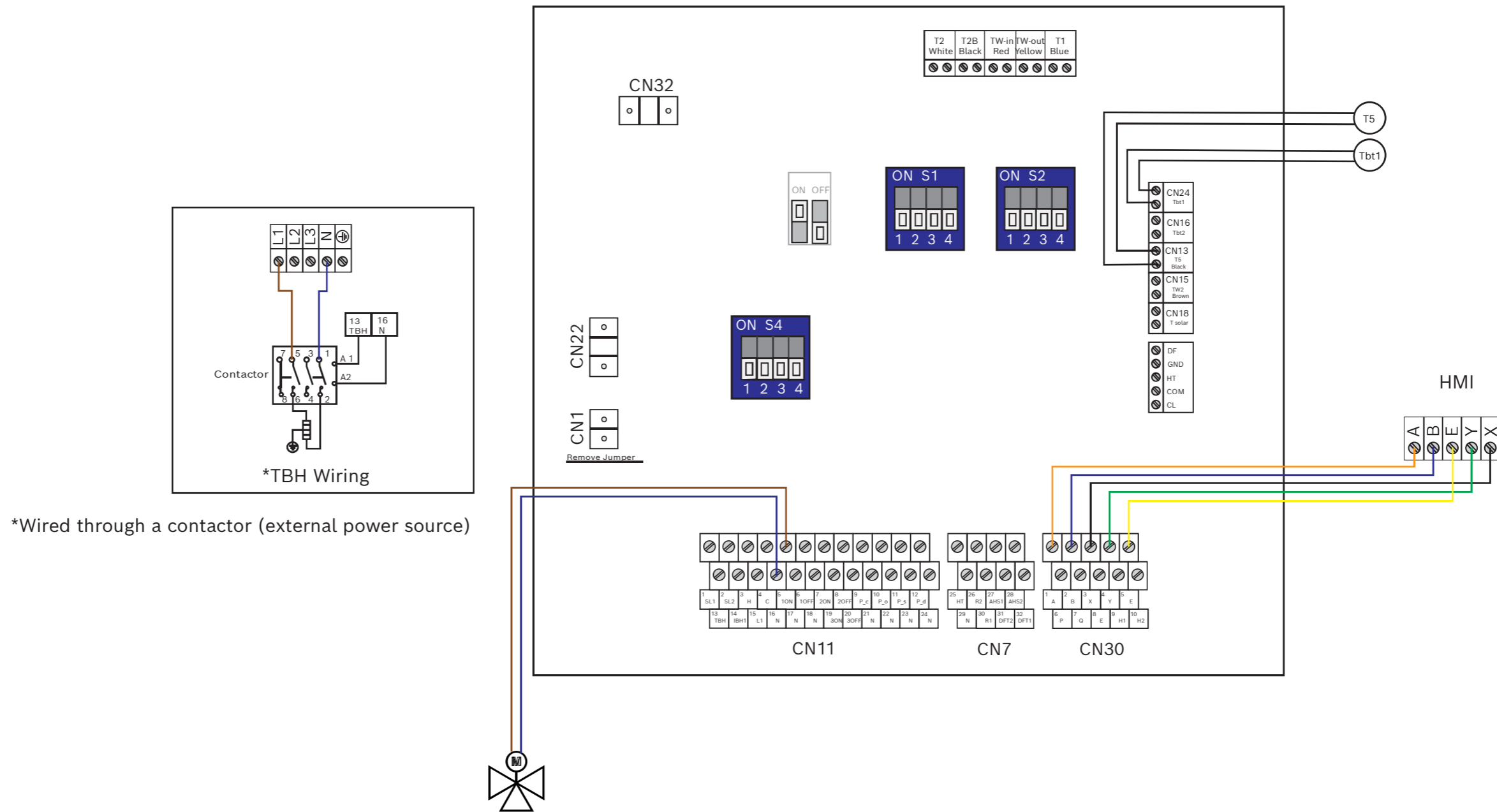

All electrical work should be carried out by a registered engineer. Wiring must comply with the latest IET wiring regulations.

Isolate the mains electricity supply before starting any work and observe all relevant safety precautions. Refer to all relevant product installation manuals for safety and installation instructions.

Whilst it is always our intention to fully assist, it is essential to recognise that all information given by the company is provided in good faith and based upon the information available. Connection labels may not match those of the products installed on site. We recommend that advice should always be checked with your installer, electrician or the manufacturer of the product in question. Consequently, the company cannot be held responsible for any liability relating to the use or repetition of such information or part thereof. In addition, whilst making every reasonable effort to monitor the performance and quality of our supply, installation and service network, we do not accept responsibility for the workmanship or operation of any third party company.

For further information or assistance please contact:
Email: system.design@uk.bosch.com Tel: 01905751464

Key	Description
	Antifreeze valve
	T1, T5, Tbt1 sensors
	Isolation valve
	Drain off valve
	Filling valve ³
	Three port valve ³
	Magnetic filter ³
	Non return valve
	3rd party controls
	Pump ³
	Pressure gauge ³
	Strainer
	Two port valves
	Immersion heater ³
	PRV ³
	Air vent ³
	High limit stat ³

CS2000AWF 4 R-S to 6 R-S ensure a minimum system volume of 30L. CS2000AWF 8 R-S to 16 R-S ensure a minimum system volume of 40L

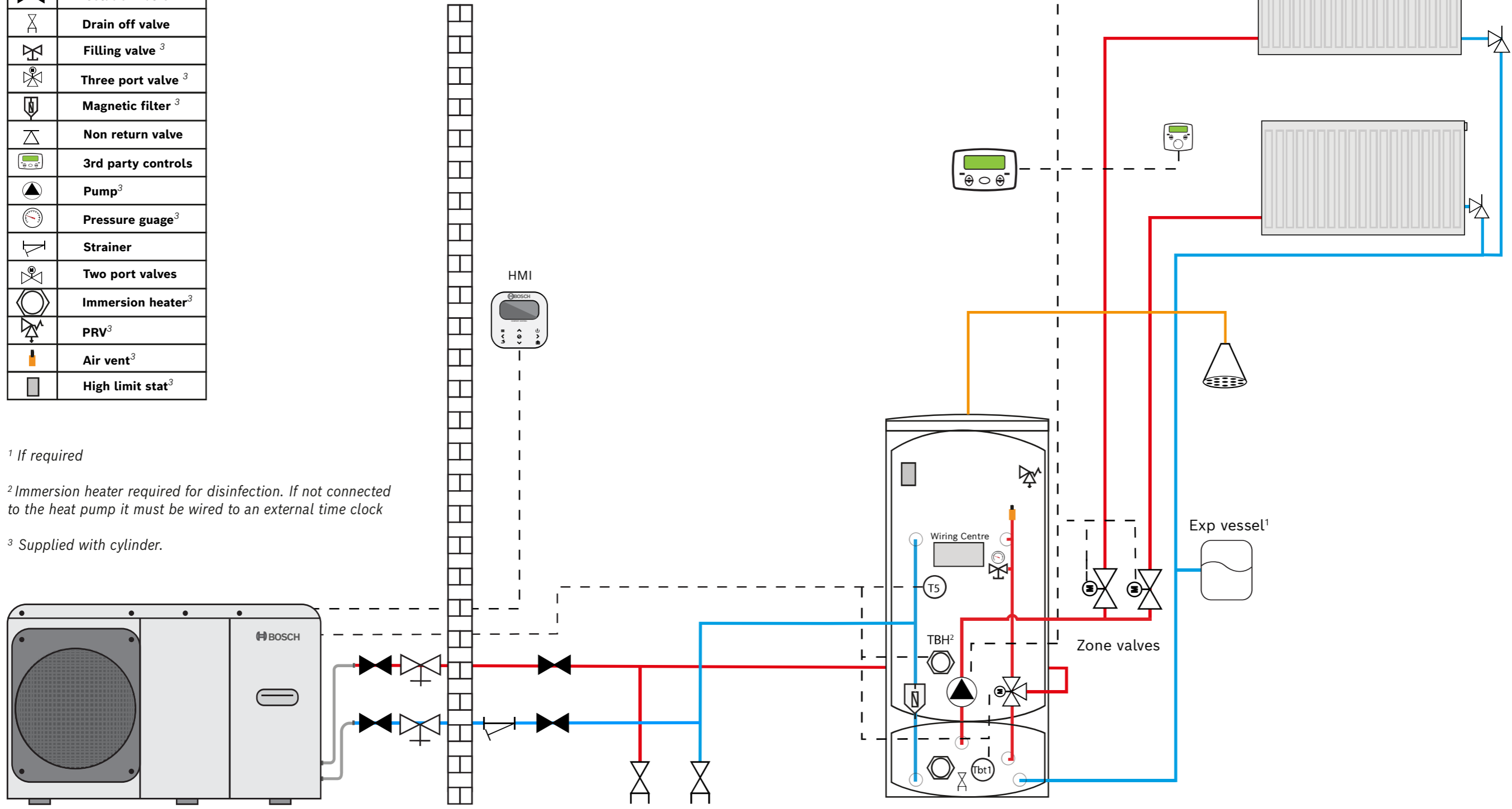

Telford Tempest HP/50L buffer pre-plumbed (2Z)

¹ If required

² Immersion heater required for disinfection. If not connected to the heat pump it must be wired to an external time clock

³ Supplied with cylinder.

All electrical work should be carried out by a registered engineer. Wiring must comply with the latest IET wiring regulations.

Isolate the mains electricity supply before starting any work and observe all relevant safety precautions. Refer to all relevant product installation manuals for safety and installation instructions.

Whilst it is always our intention to fully assist, it is essential to recognise that all information given by the company is provided in good faith and based upon the information available. Connection labels may not match those of the products installed on site. We recommend that advice should always be checked with your installer, electrician or the manufacturer of the product in question. Consequently, the company cannot be held responsible for any liability relating to the use or repetition of such information or part thereof. In addition, whilst making every reasonable effort to monitor the performance and quality of our supply, installation and service network, we do not accept responsibility for the workmanship or operation of any third party company.

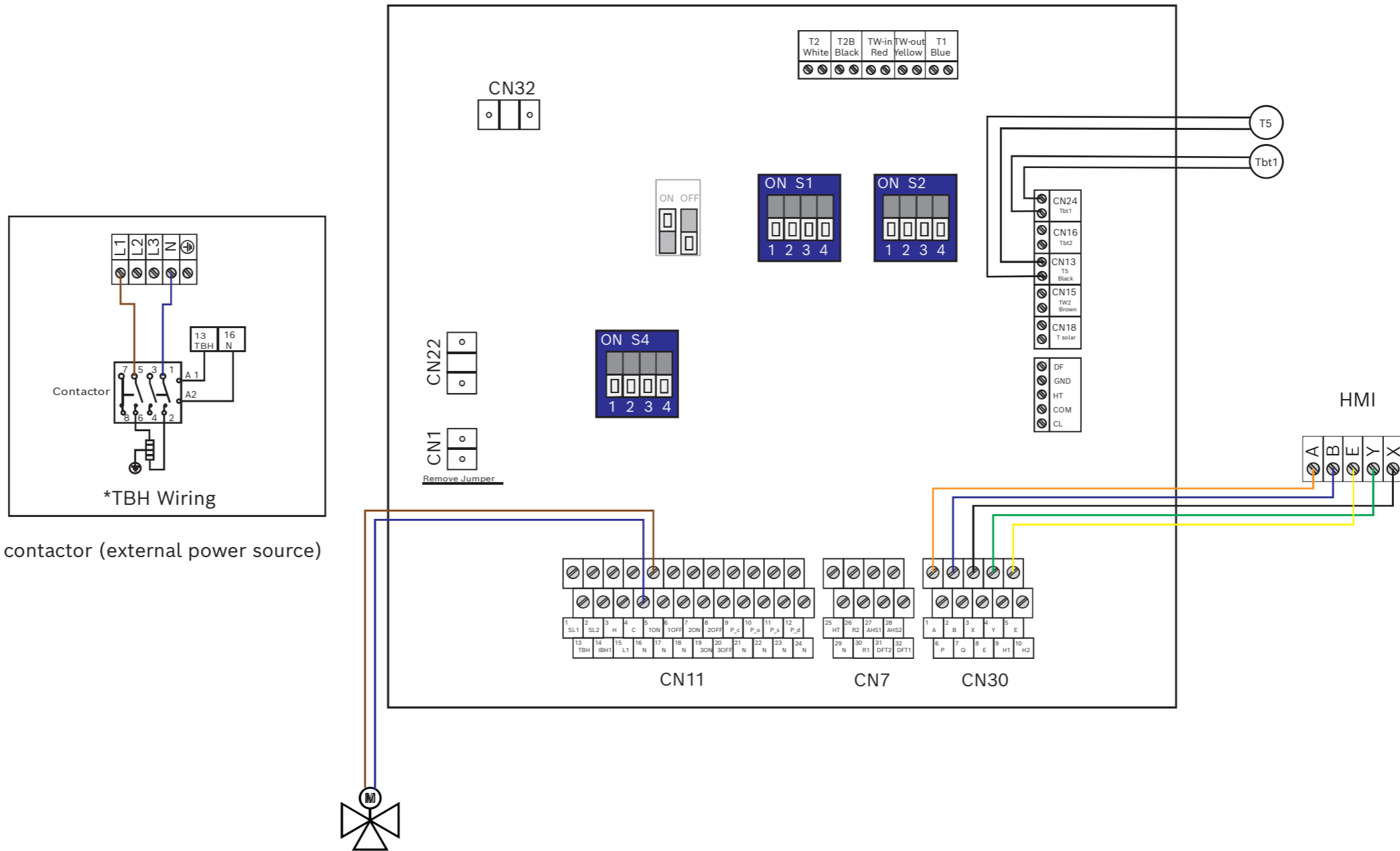

*Wired through a contactor (external power source)

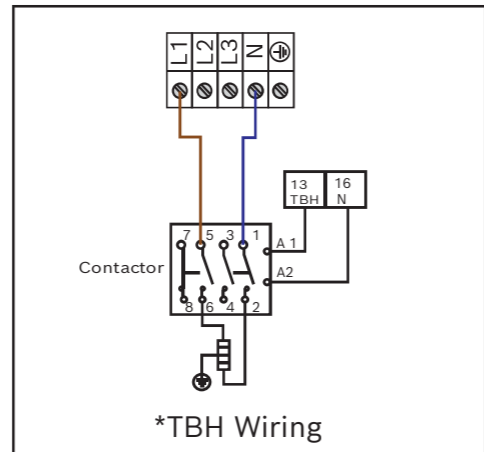

All electrical work should be carried out by a registered engineer. Wiring must comply with the latest IET wiring regulations.

Isolate the mains electricity supply before starting any work and observe all relevant safety precautions. Refer to all relevant product installation manuals for safety and installation instructions.

Whilst it is always our intention to fully assist, it is essential to recognise that all information given by the company is provided in good faith and based upon the information available. Connection labels may not match those of the products installed on site. We recommend that advice should always be checked with your installer, electrician or the manufacturer of the product in question. Consequently, the company cannot be held responsible for any liability relating to the use or repetition of such information or part thereof. In addition, whilst making every reasonable effort to monitor the performance and quality of our supply, installation and service network, we do not accept responsibility for the workmanship or operation of any third party company.

CS2000AWF 4 R-S to 6 R-S ensure a minimum system volume of 30L. CS2000AWF 8 R-S to 16 R-S ensure a minimum system volume of 40L

Key	Description
	Antifreeze valve
	T1, T5, Tbt1 sensors
	Isolation valve
	Drain off valve
	Filling valve ³
	Three port valve ³
	Magnetic filter ³
	Non return valve
	3rd party controls
	Pump ³
	Pressure gauge ³
	Strainer
	Air vent ³
	Immersion heater ³
	PRV ³
	High limit stat ³

¹ If required

² Immersion heater required for disinfection. If not connected to the heat pump it must be wired to an external time clock

³ Supplied with cylinder.

⁴ If HMI is used as a stat or programmable stat is wired to heat pump the heating circuit pump must be wired to heat pump via a contactor. See wiring.

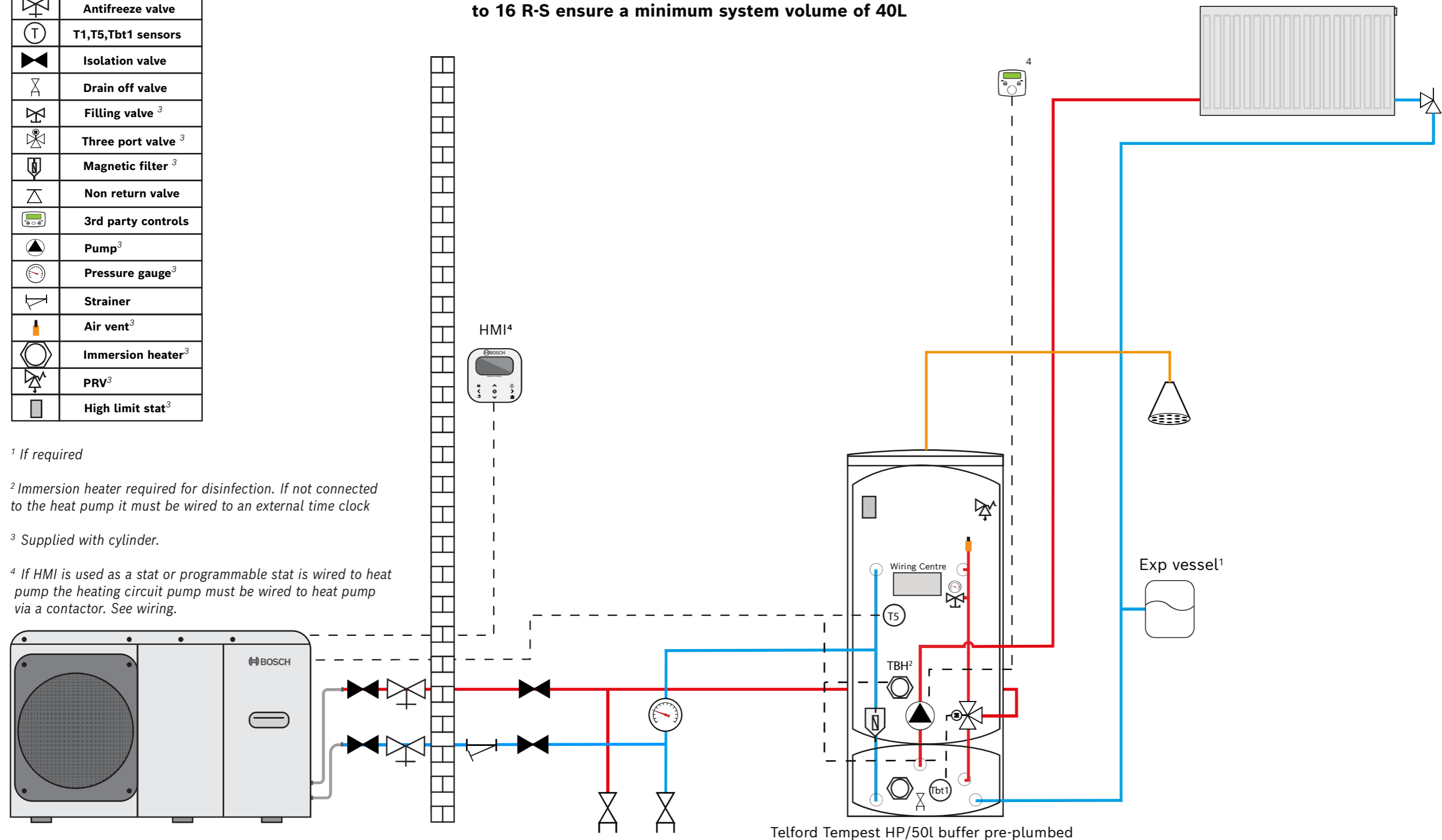

Telford Tempest HP/50L buffer pre-plumbed

All electrical work should be carried out by a registered engineer. Wiring must comply with the latest IET wiring regulations.

Isolate the mains electricity supply before starting any work and observe all relevant safety precautions. Refer to all relevant product installation manuals for safety and installation instructions.

Whilst it is always our intention to fully assist, it is essential to recognise that all information given by the company is provided in good faith and based upon the information available. Connection labels may not match those of the products installed on site. We recommend that advice should always be checked with your installer, electrician or the manufacturer of the product in question. Consequently, the company cannot be held responsible for any liability relating to the use or repetition of such information or part thereof. In addition, whilst making every reasonable effort to monitor the performance and quality of our supply, installation and service network, we do not accept responsibility for the workmanship or operation of any third party company.

For further information or assistance please contact:
 Email: system.design@uk.bosch.com Tel: 01905751464

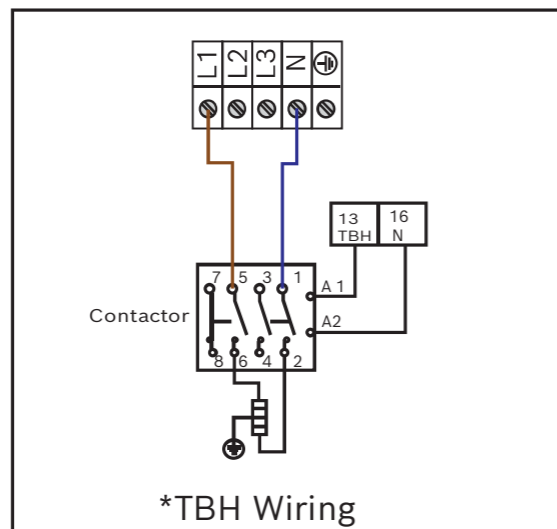
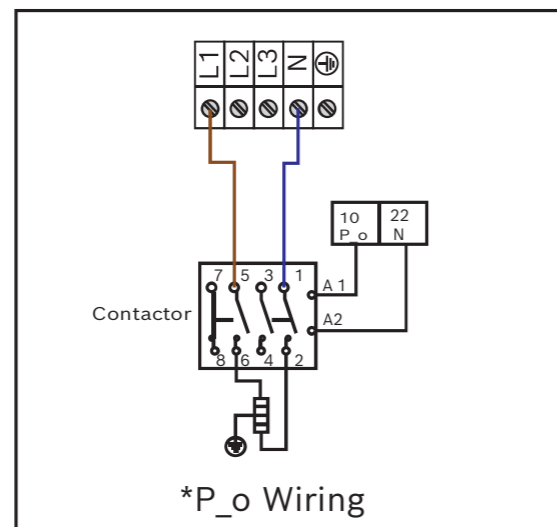





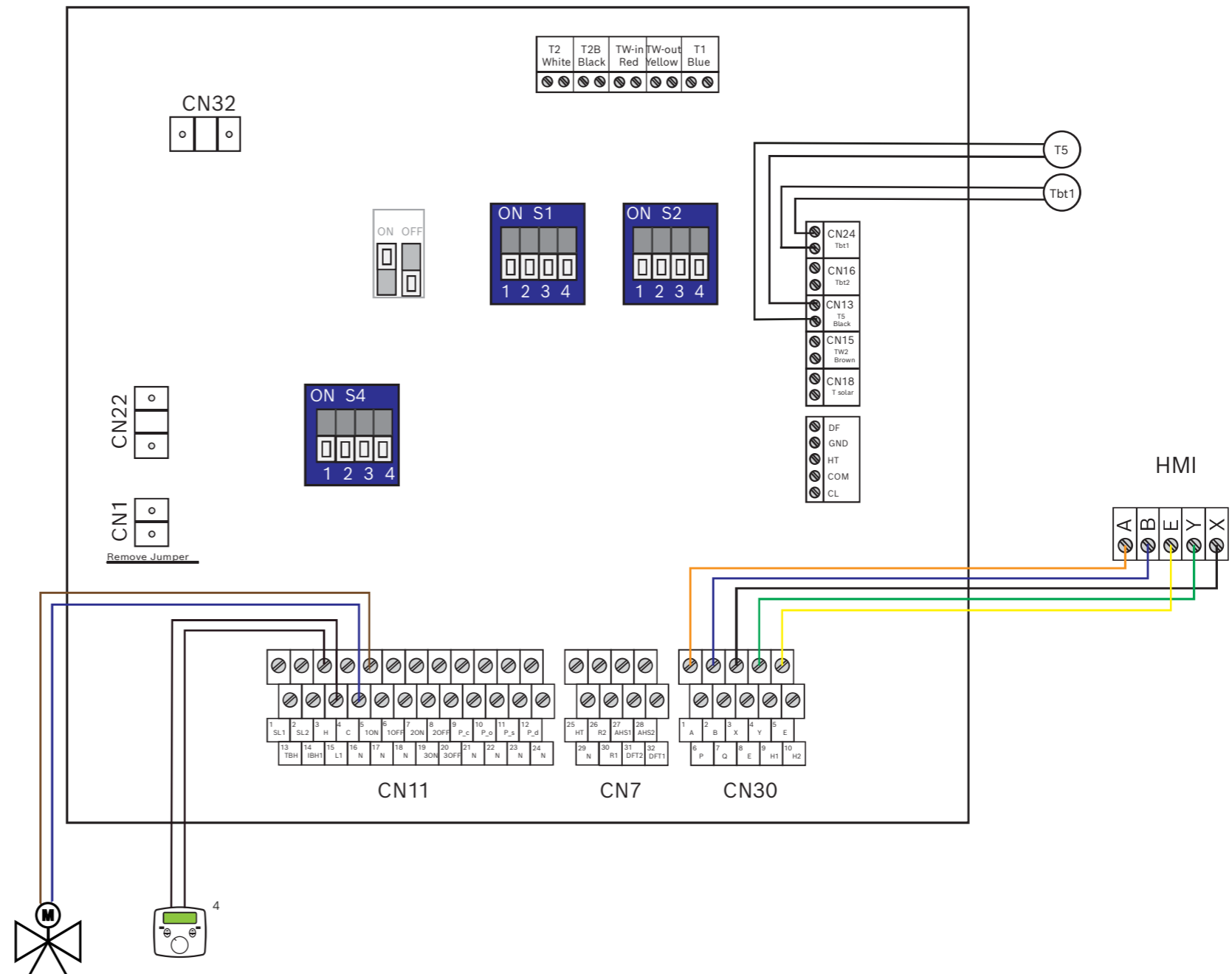











*Wired through a contactor (external power source)

⁴ If HMI is used as a stat or programmable stat is wired to heat pump the heating circuit pump (P_o) must be wired to heat pump via a contactor.





Key	Description
	Antifreeze valve
	T1, T5, Tbt1 sensors
	Isolation valve
	Drain off valve
	Filling valve ³
	Three port valve ³
	Magnetic filter
	Air separator
	3rd party controls
	Pump ³
	Pressure gauge ³
	Strainer
	Two port valve
	Immersion heater ³
	PRV ³
	Fill and flush ³

CS2000AWF 4 R-S to 6 R-S ensure a minimum system volume of 30L. CS2000AWF 8 R-S to 16 R-S ensure a minimum system volume of 40L

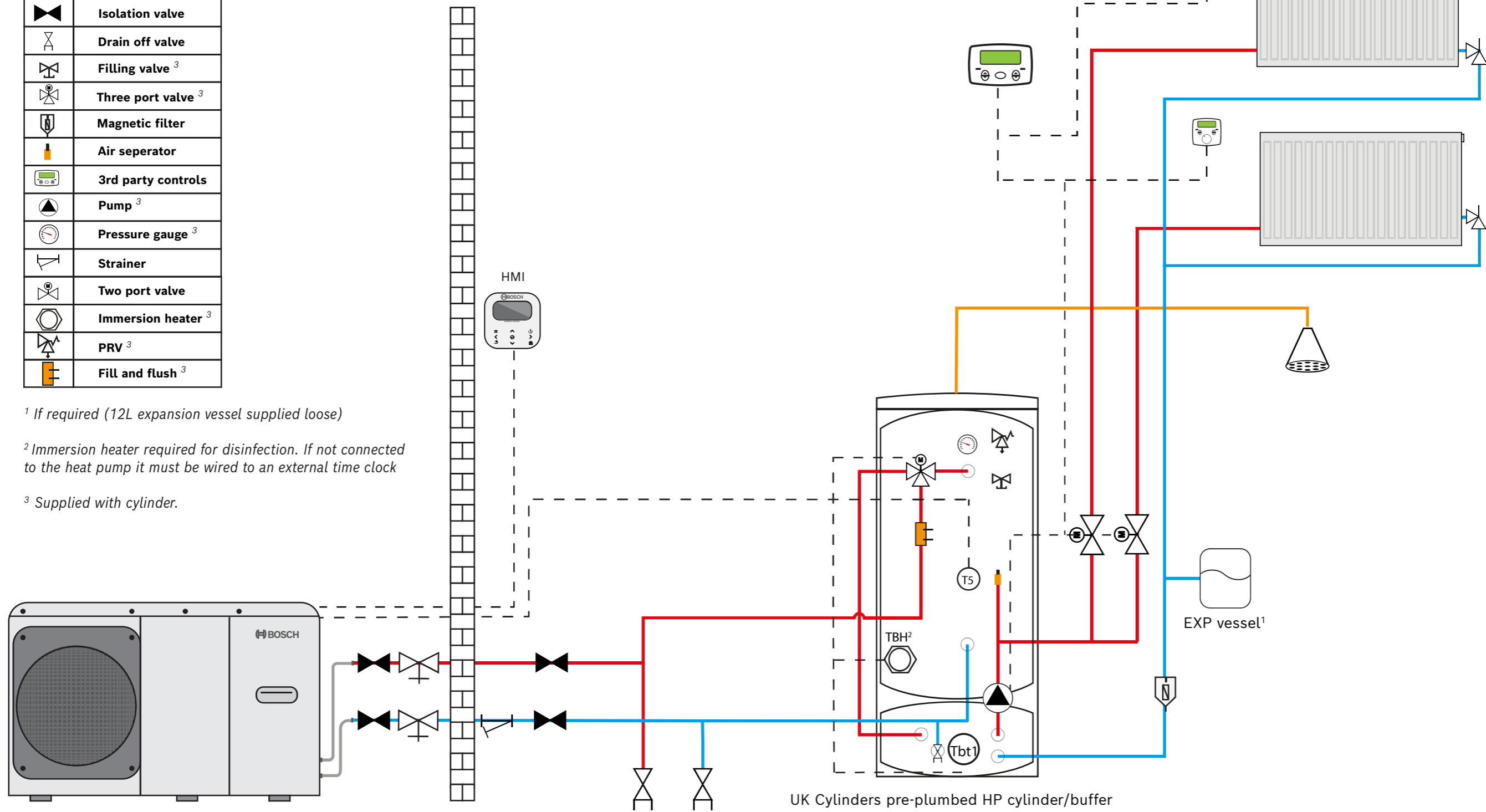

¹ If required (12L expansion vessel supplied loose)

² Immersion heater required for disinfection. If not connected to the heat pump it must be wired to an external time clock

³ Supplied with cylinder.

All electrical work should be carried out by a registered engineer. Wiring must comply with the latest IET wiring regulations.

Isolate the mains electricity supply before starting any work and observe all relevant safety precautions. Refer to all relevant product installation manuals for safety and installation instructions.

Whilst it is always our intention to fully assist, it is essential to recognise that all information given by the company is provided in good faith and based upon the information available. Connection labels may not match those of the products installed on site. We recommend that advice should always be checked with your installer, electrician or the manufacturer of the product in question. Consequently, the company cannot be held responsible for any liability relating to the use or repetition of such information or part thereof. In addition, whilst making every reasonable effort to monitor the performance and quality of our supply, installation and service network, we do not accept responsibility for the workmanship or operation of any third party company.

For further information or assistance please contact:
Email: system.design@uk.bosch.com Tel: 01905751464

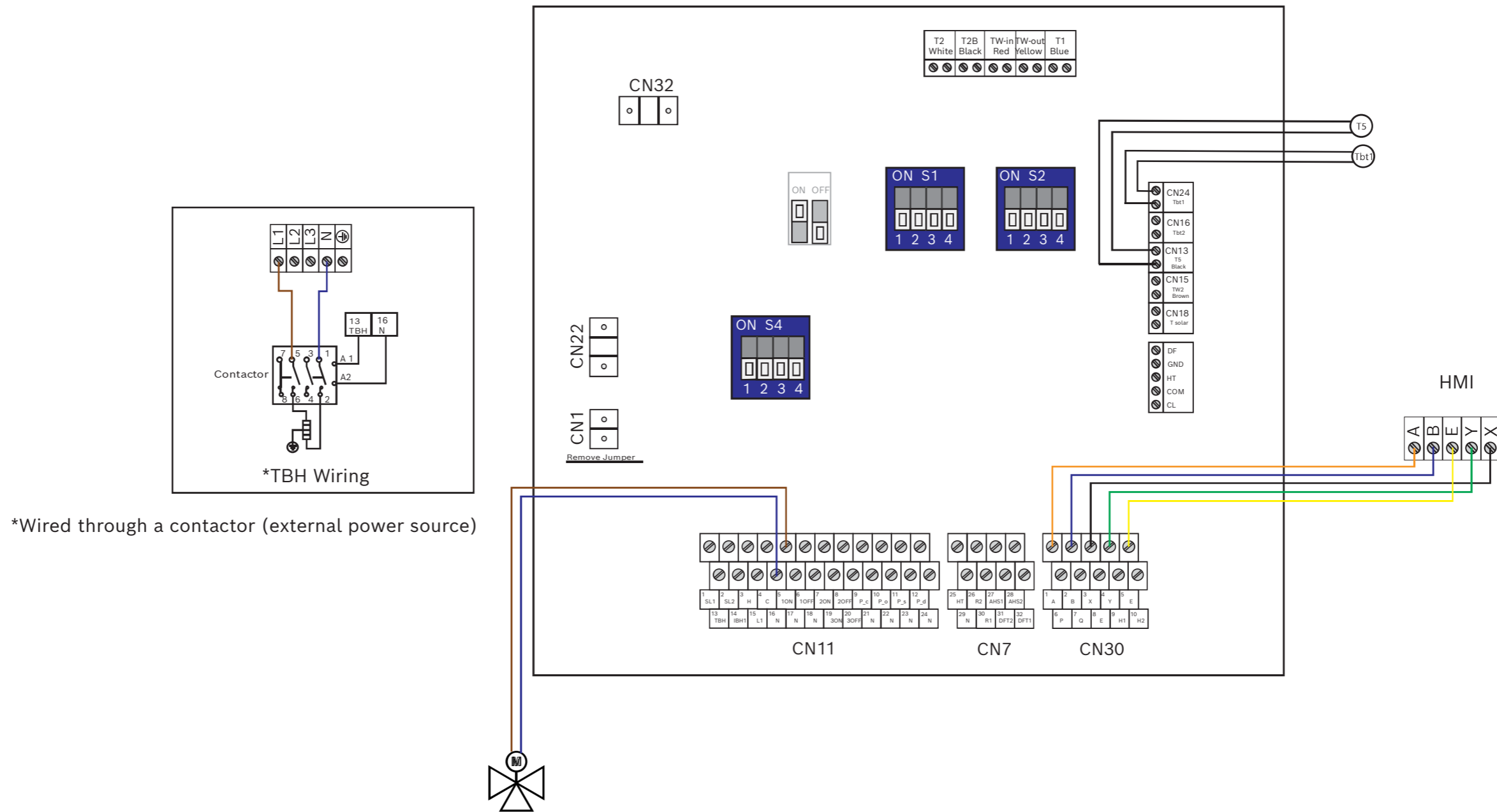

















All electrical work should be carried out by a registered engineer. Wiring must comply with the latest IET wiring regulations.

Isolate the mains electricity supply before starting any work and observe all relevant safety precautions. Refer to all relevant product installation manuals for safety and installation instructions.

Whilst it is always our intention to fully assist, it is essential to recognise that all information given by the company is provided in good faith and based upon the information available. Connection labels may not match those of the products installed on site. We recommend that advice should always be checked with your installer, electrician or the manufacturer of the product in question. Consequently, the company cannot be held responsible for any liability relating to the use or repetition of such information or part thereof. In addition, whilst making every reasonable effort to monitor the performance and quality of our supply, installation and service network, we do not accept responsibility for the workmanship or operation of any third party company.

For further information or assistance please contact:
 Email: system.design@uk.bosch.com Tel: 01905751464

Key	Description
	Antifreeze valve
	T1, T5, Tbt1 sensors
	Isolation valve
	Drain off valve
	Filling valve ³
	Three port valve ³
	Magnetic filter
	Air separator
	3rd party controls
	Pump ³
	Pressure gauge ³
	Strainer
	Two port valve
	Immersion heater ³
	PRV ³
	Fill and flush ³

CS2000AWF 4 R-S to 6 R-S ensure a minimum system volume of 30L. CS2000AWF 8 R-S to 16 R-S ensure a minimum system volume of 40L

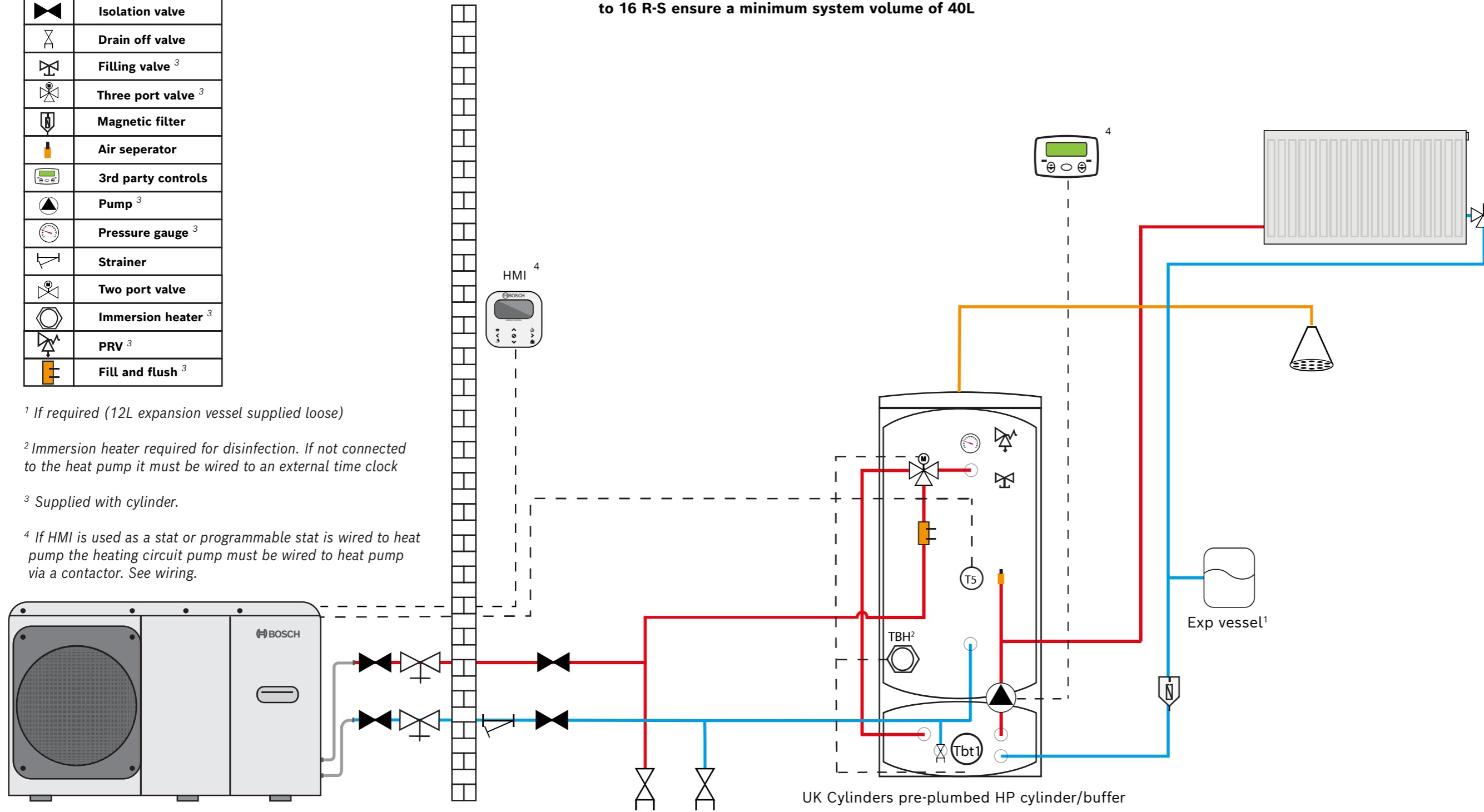

- ¹ If required (12L expansion vessel supplied loose)
- ² Immersion heater required for disinfection. If not connected to the heat pump it must be wired to an external time clock
- ³ Supplied with cylinder.
- ⁴ If HMI is used as a stat or programmable stat is wired to heat pump the heating circuit pump must be wired to heat pump via a contactor. See wiring.

All electrical work should be carried out by a registered engineer. Wiring must comply with the latest IET wiring regulations. Isolate the mains electricity supply before starting any work and observe all relevant safety precautions. Refer to all relevant product installation manuals for safety and installation instructions. Whilst it is always our intention to fully assist, it is essential to recognise that all information given by the company is provided in good faith and based upon the information available. Connection labels may not match those of the products installed on site. We recommend that advice should always be checked with your installer, electrician or the manufacturer of the product in question. Consequently, the company cannot be held responsible for any liability relating to the use or repetition of such information or part thereof. In addition, whilst making every reasonable effort to monitor the performance and quality of our supply, installation and service network, we do not accept responsibility for the workmanship or operation of any third party company.

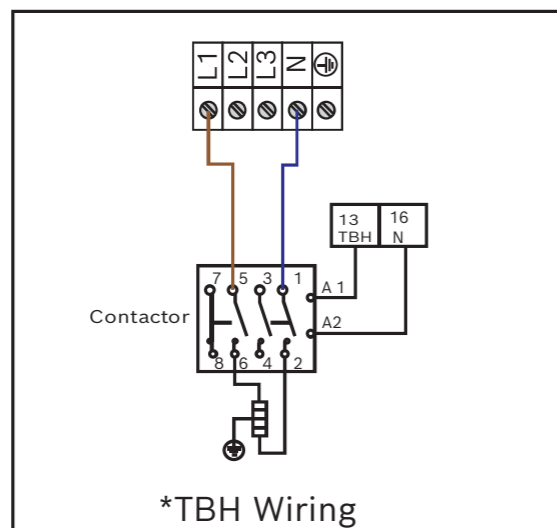
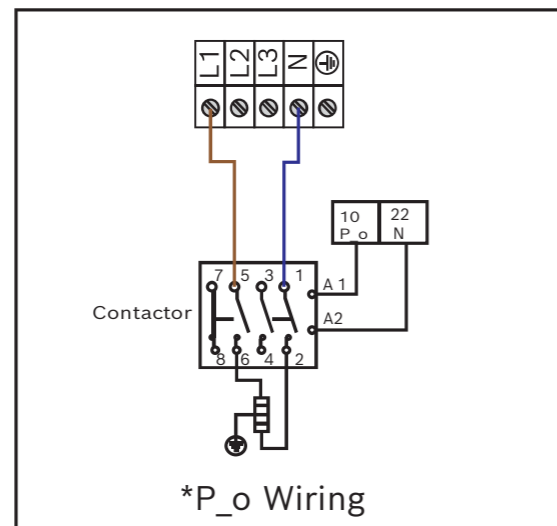
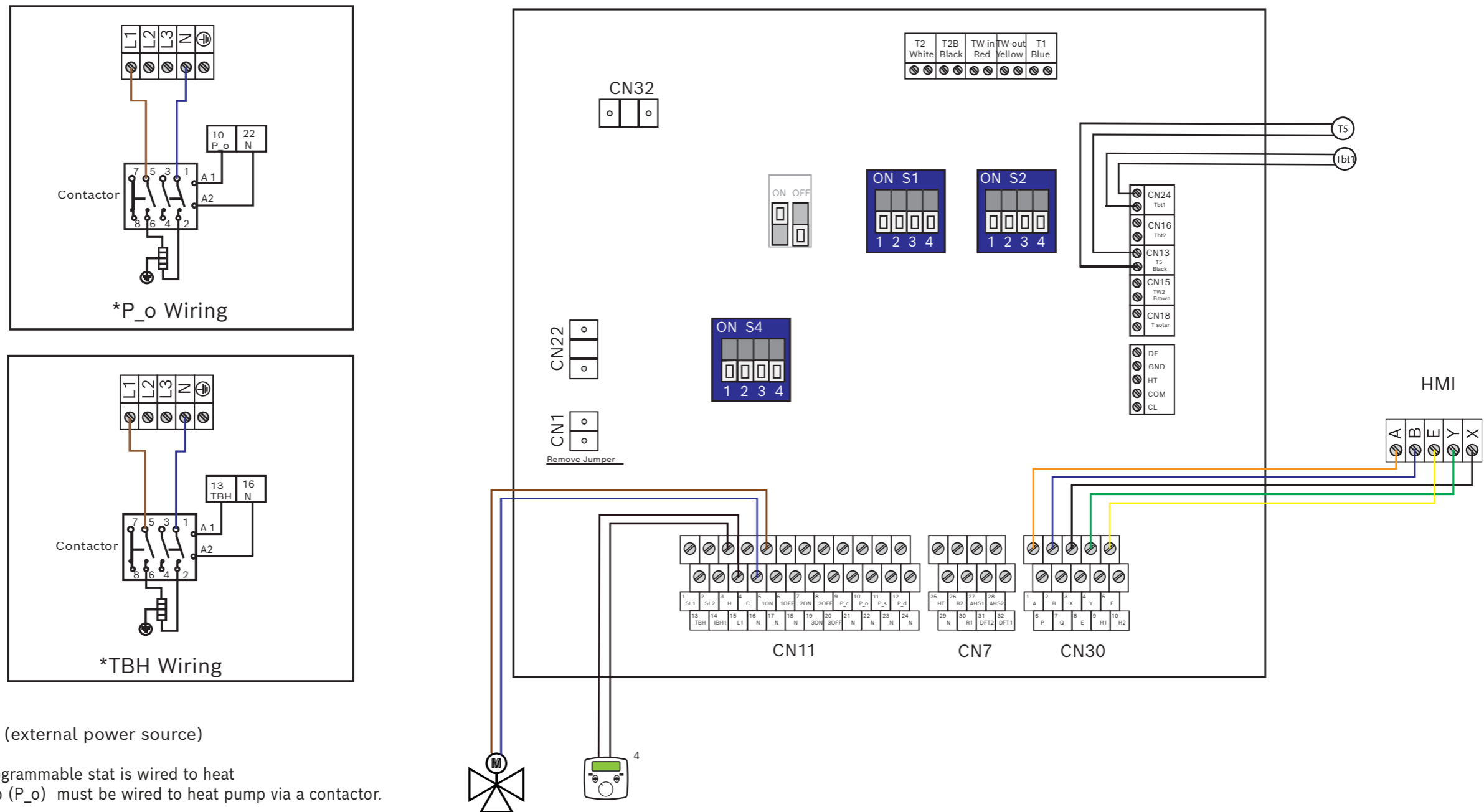

*Wired through a contactor (external power source)

⁴ If HMI is used as a stat or programmable stat is wired to heat pump the heating circuit pump (P_o) must be wired to heat pump via a contactor.

Key	Description
	Antifreeze valve
	T1, T5, Tbt1 sensors
	Isolation valve
	Drain off valve
	Filling valve ³
	Three port valve ³
	Magnetic filter
	Non return valve
	3rd Party controls
	Pump
	Pressure gauge ³
	Strainer
	Immersion heater ³
	PRV ³

CS2000AWF 4 R-S to 6 R-S ensure a minimum system volume of 30L. CS2000AWF 8 R-S to 16 R-S ensure a minimum system volume of 40L

¹ If required

² Immersion heater required for disinfection. If not connected to the heat pump it must be wired to an external time clock

³ Supplied with cylinder.

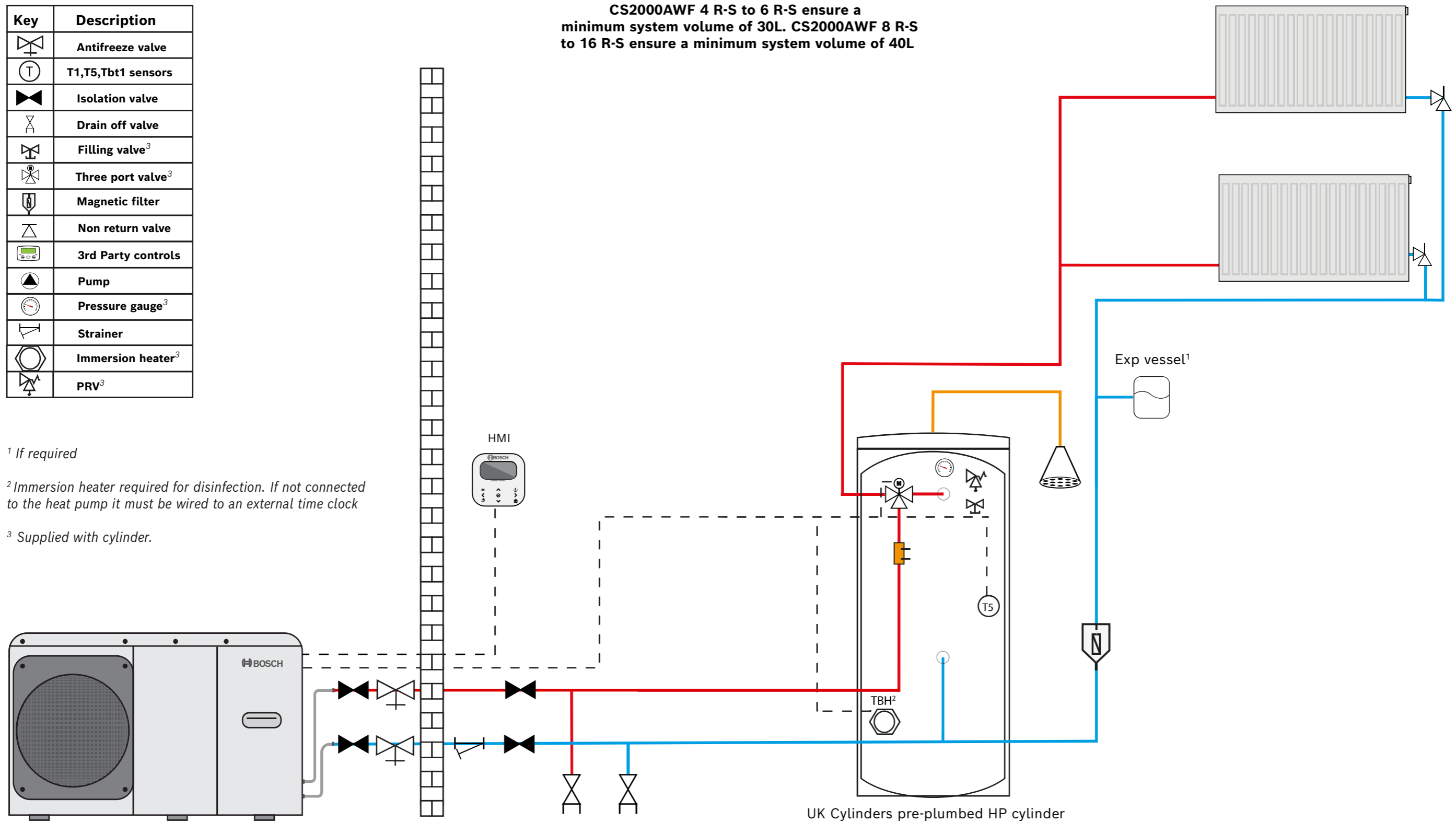

All electrical work should be carried out by a registered engineer. Wiring must comply with the latest IET wiring regulations.

Isolate the mains electricity supply before starting any work and observe all relevant safety precautions. Refer to all relevant product installation manuals for safety and installation instructions.

Whilst it is always our intention to fully assist, it is essential to recognise that all information given by the company is provided in good faith and based upon the information available. Connection labels may not match those of the products installed on site. We recommend that advice should always be checked with your installer, electrician or the manufacturer of the product in question. Consequently, the company cannot be held responsible for any liability relating to the use or repetition of such information or part thereof. In addition, whilst making every reasonable effort to monitor the performance and quality of our supply, installation and service network, we do not accept responsibility for the workmanship or operation of any third party company.

For further information or assistance please contact:

Email: system.design@uk.bosch.com Tel: 01905751464

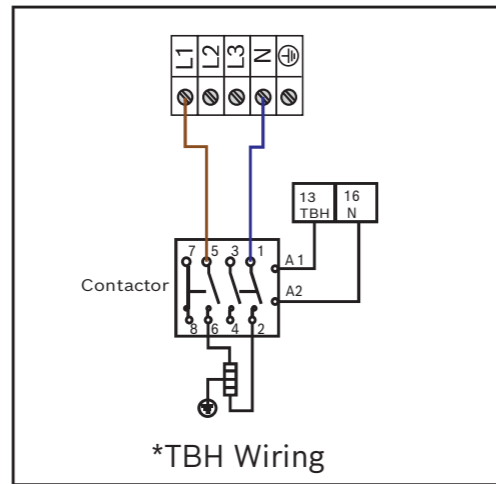
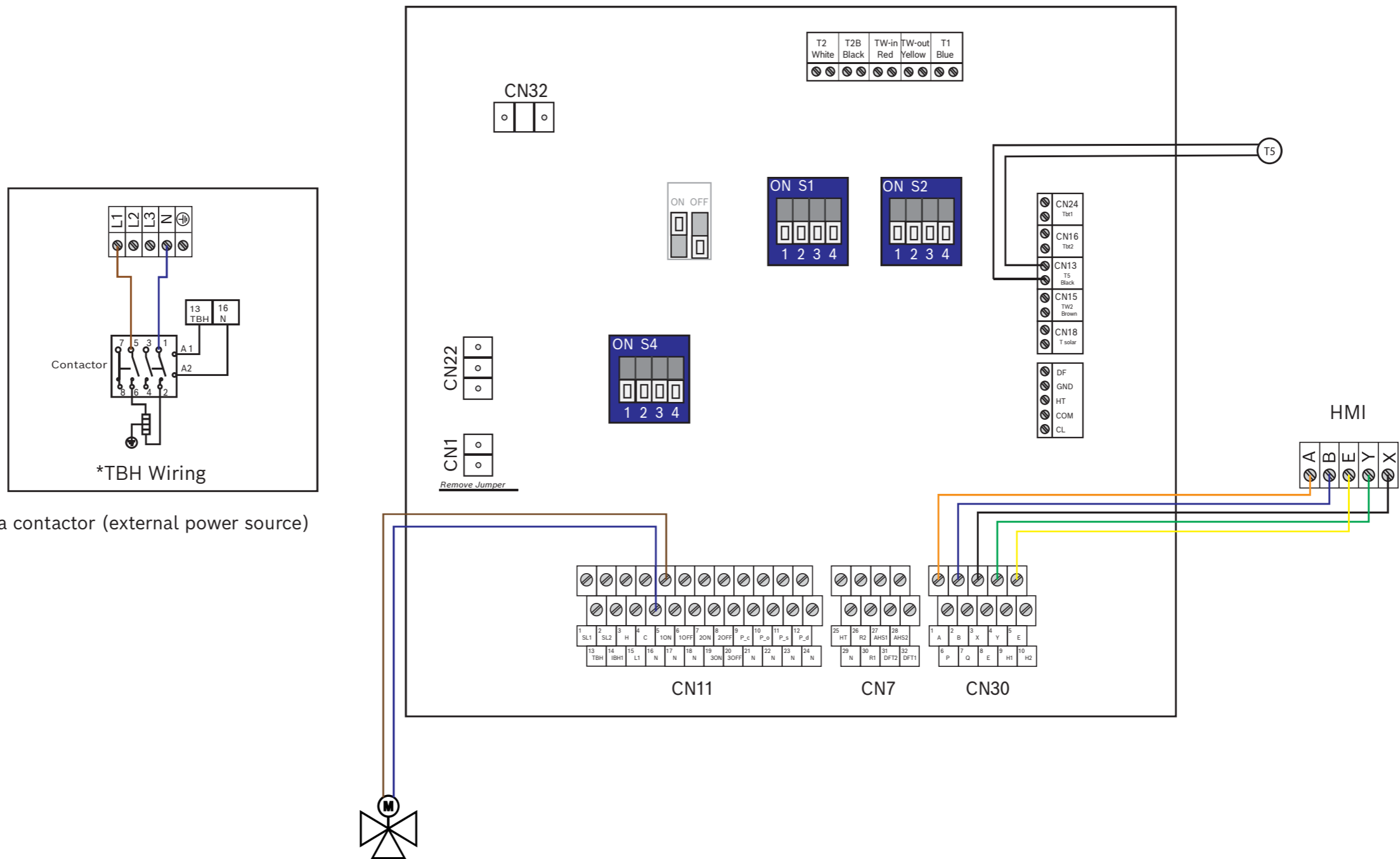















*Wired through a contactor (external power source)

All electrical work should be carried out by a registered engineer. Wiring must comply with the latest IET wiring regulations.

Isolate the mains electricity supply before starting any work and observe all relevant safety precautions. Refer to all relevant product installation manuals for safety and installation instructions.

Whilst it is always our intention to fully assist, it is essential to recognise that all information given by the company is provided in good faith and based upon the information available. Connection labels may not match those of the products installed on site. We recommend that advice should always be checked with your installer, electrician or the manufacturer of the product in question. Consequently, the company cannot be held responsible for any liability relating to the use or repetition of such information or part thereof. In addition, whilst making every reasonable effort to monitor the performance and quality of our supply, installation and service network, we do not accept responsibility for the workmanship or operation of any third party company.



Key	Description
	Antifreeze valve
	T1, T5, Tbt1 sensors
	Isolation valve
	Drain off valve
	Filling valve
	Three port valve
	Magnetic filter
	Non return valve
	3rd Party controls
	Pump
	Pressure gauge
	Strainer
	Immersion heater ³
	PRV ³

¹ If required

² Immersion heater required for disinfection. If not connected to the heat pump it must be wired to an external time clock. Destratification pump programmed to operate via the HMI.

³ Supplied with cylinder.

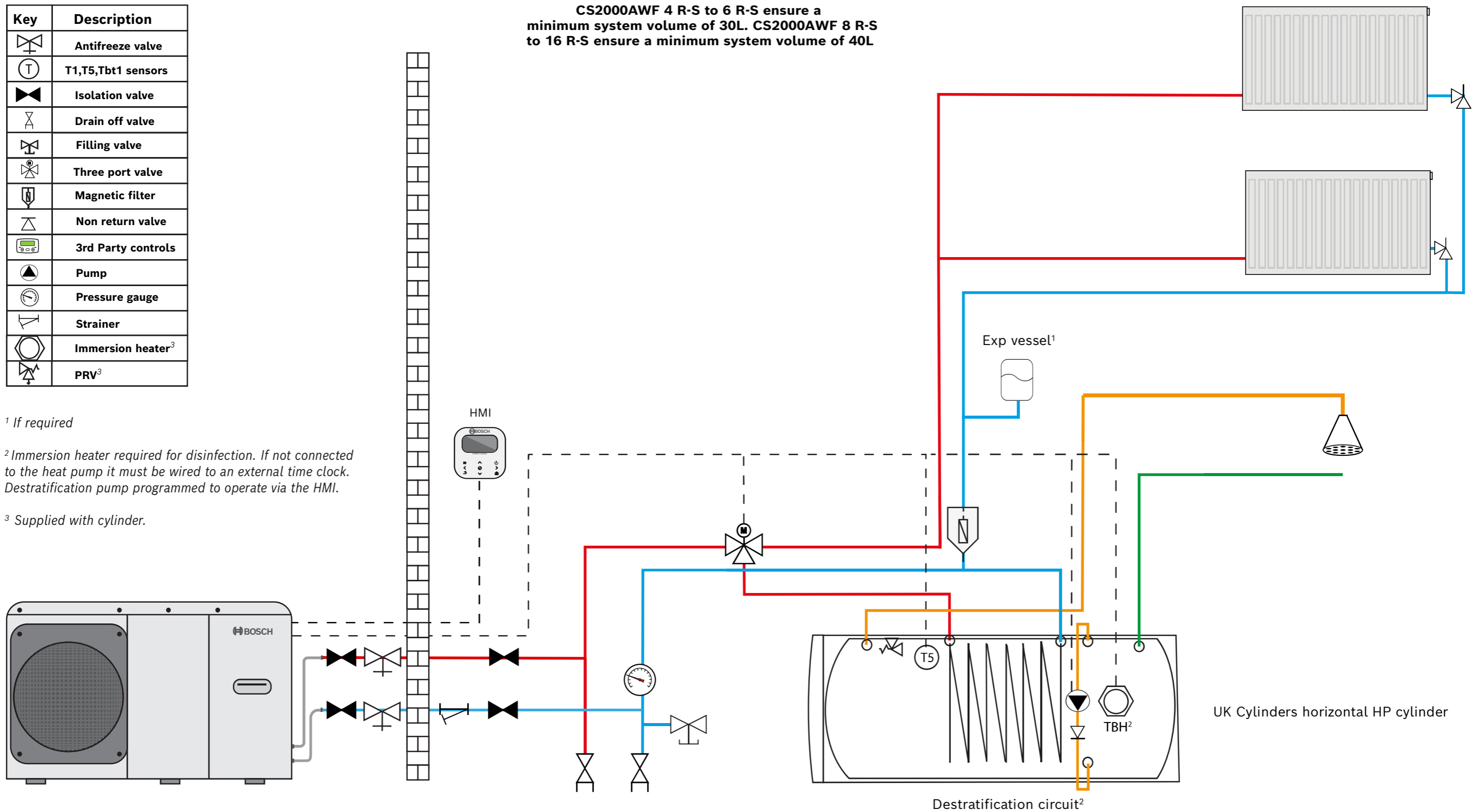

All electrical work should be carried out by a registered engineer. Wiring must comply with the latest IET wiring regulations. Isolate the mains electricity supply before starting any work and observe all relevant safety precautions. Refer to all relevant product installation manuals for safety and installation instructions. Whilst it is always our intention to fully assist, it is essential to recognise that all information given by the company is provided in good faith and based upon the information available. Connection labels may not match those of the products installed on site. We recommend that advice should always be checked with your installer, electrician or the manufacturer of the product in question. Consequently, the company cannot be held responsible for any liability relating to the use or repetition of such information or part thereof. In addition, whilst making every reasonable effort to monitor the performance and quality of our supply, installation and service network, we do not accept responsibility for the workmanship or operation of any third party company.

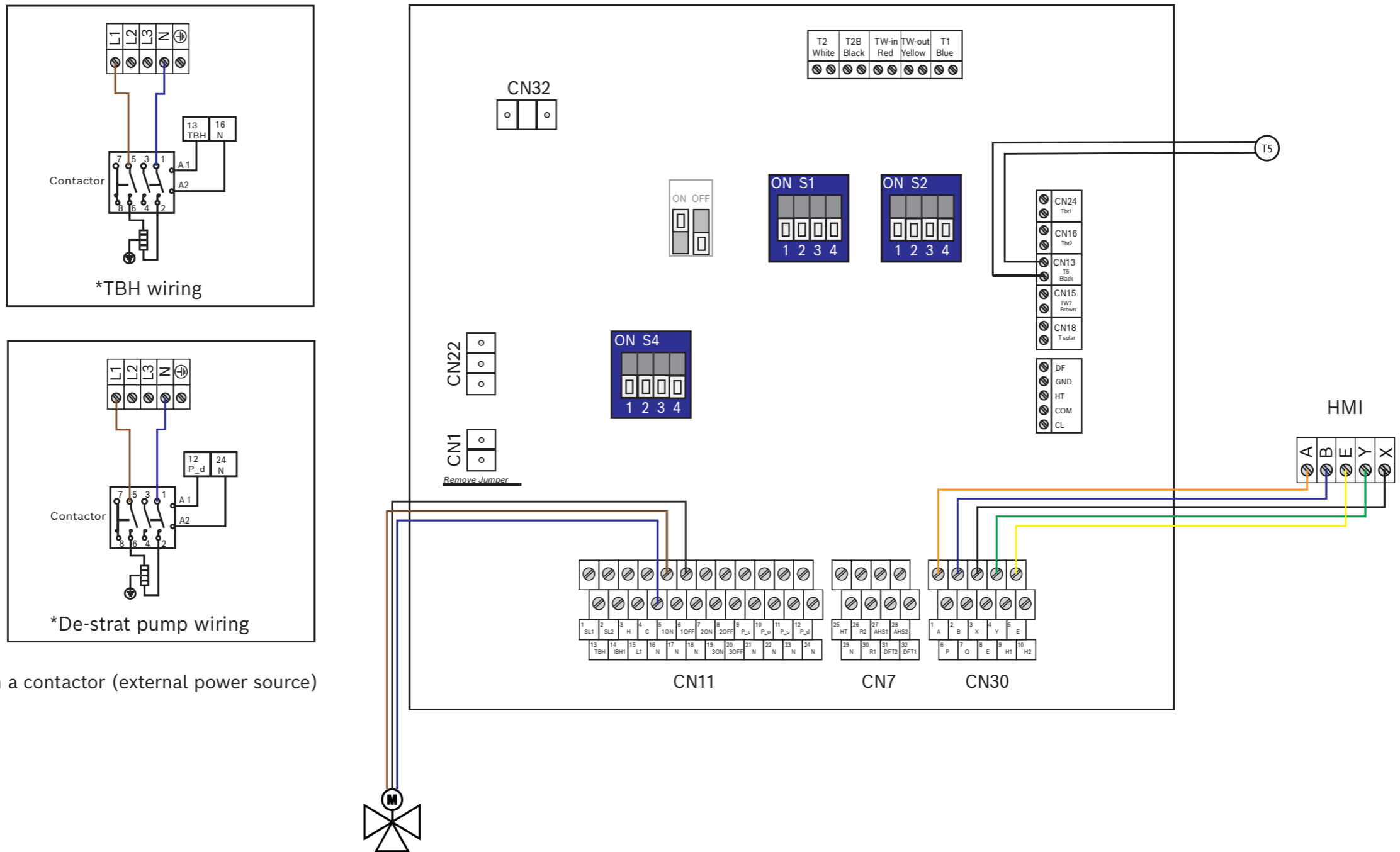

If a third party diverter valve is used wiring and orientation may differ. Seek advice for compatible products

All electrical work should be carried out by a registered engineer. Wiring must comply with the latest IET wiring regulations.

Isolate the mains electricity supply before starting any work and observe all relevant safety precautions. Refer to all relevant product installation manuals for safety and installation instructions.

Whilst it is always our intention to fully assist, it is essential to recognise that all information given by the company is provided in good faith and based upon the information available. Connection labels may not match those of the products installed on site. We recommend that advice should always be checked with your installer, electrician or the manufacturer of the product in question. Consequently, the company cannot be held responsible for any liability relating to the use or repetition of such information or part thereof. In addition, whilst making every reasonable effort to monitor the performance and quality of our supply, installation and service network, we do not accept responsibility for the workmanship or operation of any third party company.

For further information or assistance please contact:
 Email: system.design@uk.bosch.com Tel: 01905751464



Key	Description
	Antifreeze valve
	T1, T5, Tbt1 sensors
	Isolation valve
	Drain off valve
	Filling valve
	Three port valve
	Magnetic filter
	Non return valve
	3rd party controls
	Pump
	Pressure gauge
	Strainer
	Two port valve
	Immersion heater ³
	PRV ³

¹ If required

² Immersion heater required for disinfection. If not connected to the heat pump it must be wired to an external time clock. Destratification pump programmed to operate via the HMI.

³ Supplied with cylinder. (Note: 1 Two port valve supplied)

CS2000AWF 4 R-S to 6 R-S ensure a minimum system volume of 30L. CS2000AWF 8 R-S to 16 R-S ensure a minimum system volume of 40L

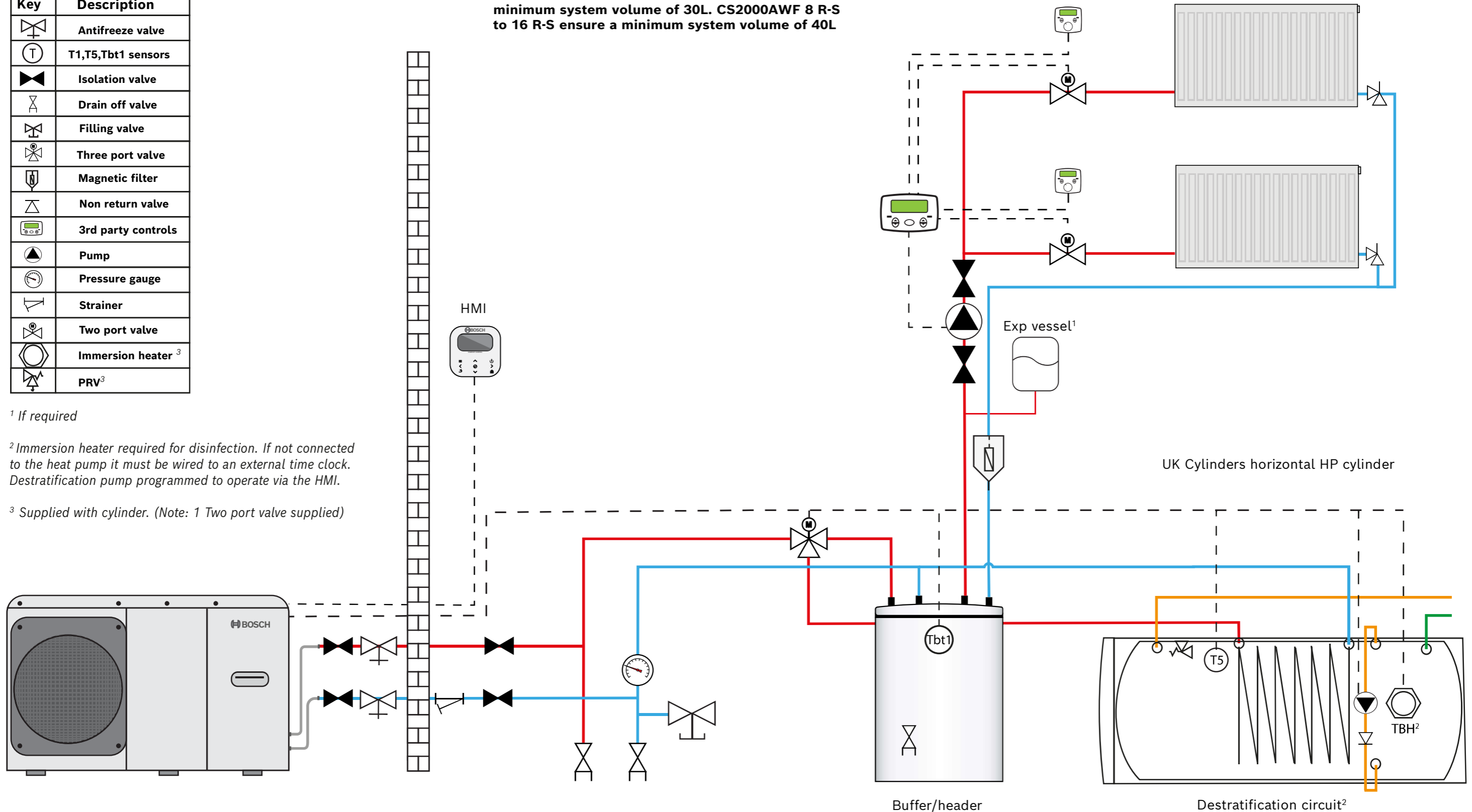

All electrical work should be carried out by a registered engineer. Wiring must comply with the latest IET wiring regulations.

Isolate the mains electricity supply before starting any work and observe all relevant safety precautions. Refer to all relevant product installation manuals for safety and installation instructions.

Whilst it is always our intention to fully assist, it is essential to recognise that all information given by the company is provided in good faith and based upon the information available. Connection labels may not match those of the products installed on site. We recommend that advice should always be checked with your installer, electrician or the manufacturer of the product in question. Consequently, the company cannot be held responsible for any liability relating to the use or repetition of such information or part thereof. In addition, whilst making every reasonable effort to monitor the performance and quality of our supply, installation and service network, we do not accept responsibility for the workmanship or operation of any third party company.



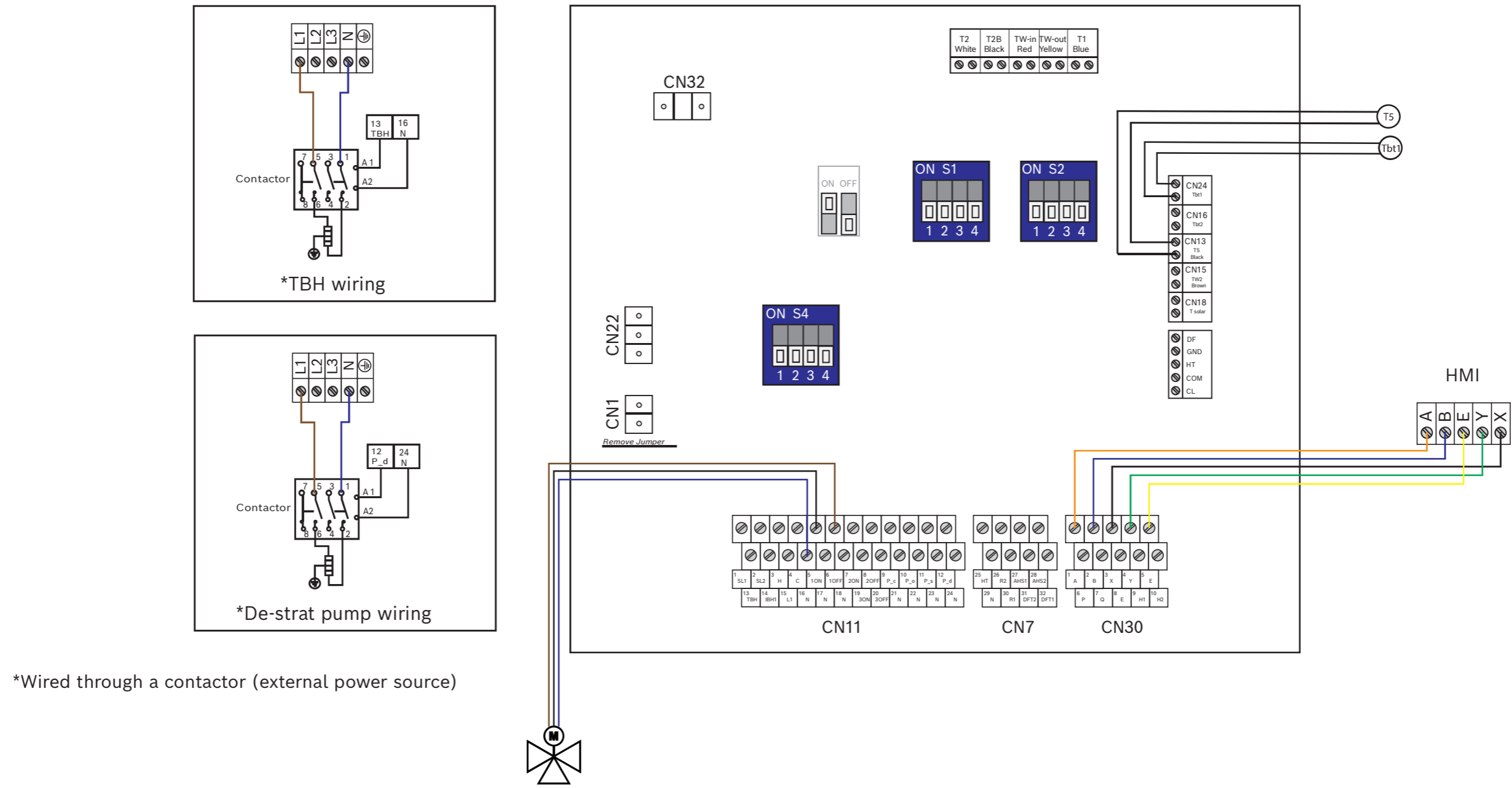



For further information or assistance please contact:
Email: system.design@uk.bosch.com Tel: 01905751464



If a third party diverter valve is used wiring and orientation may differ. Seek advice for compatible products

All electrical work should be carried out by a registered engineer. Wiring must comply with the latest IET wiring regulations. Isolate the mains electricity supply before starting any work and observe all relevant safety precautions. Refer to all relevant product installation manuals for safety and installation instructions. Whilst it is always our intention to fully assist, it is essential to recognise that all information given by the company is provided in good faith and based upon the information available. Connection labels may not match those of the products installed on site. We recommend that advice should always be checked with your installer, electrician or the manufacturer of the product in question. Consequently, the company cannot be held responsible for any liability relating to the use or repetition of such information or part thereof. In addition, whilst making every reasonable effort to monitor the performance and quality of our supply, installation and service network, we do not accept responsibility for the workmanship or operation of any third party company.



Key	Description
	Antifreeze Valve
	Isolation Valve
	Drain off Valve
	Filling Valve
	Magnetic Filter
	Pressure gauge
	Strainer

¹ If required

CS2000AWF 4 R-S to 6 R-S ensure a minimum system volume of 30L. CS2000AWF 8 R-S to 16 R-S ensure a minimum system volume of 40L

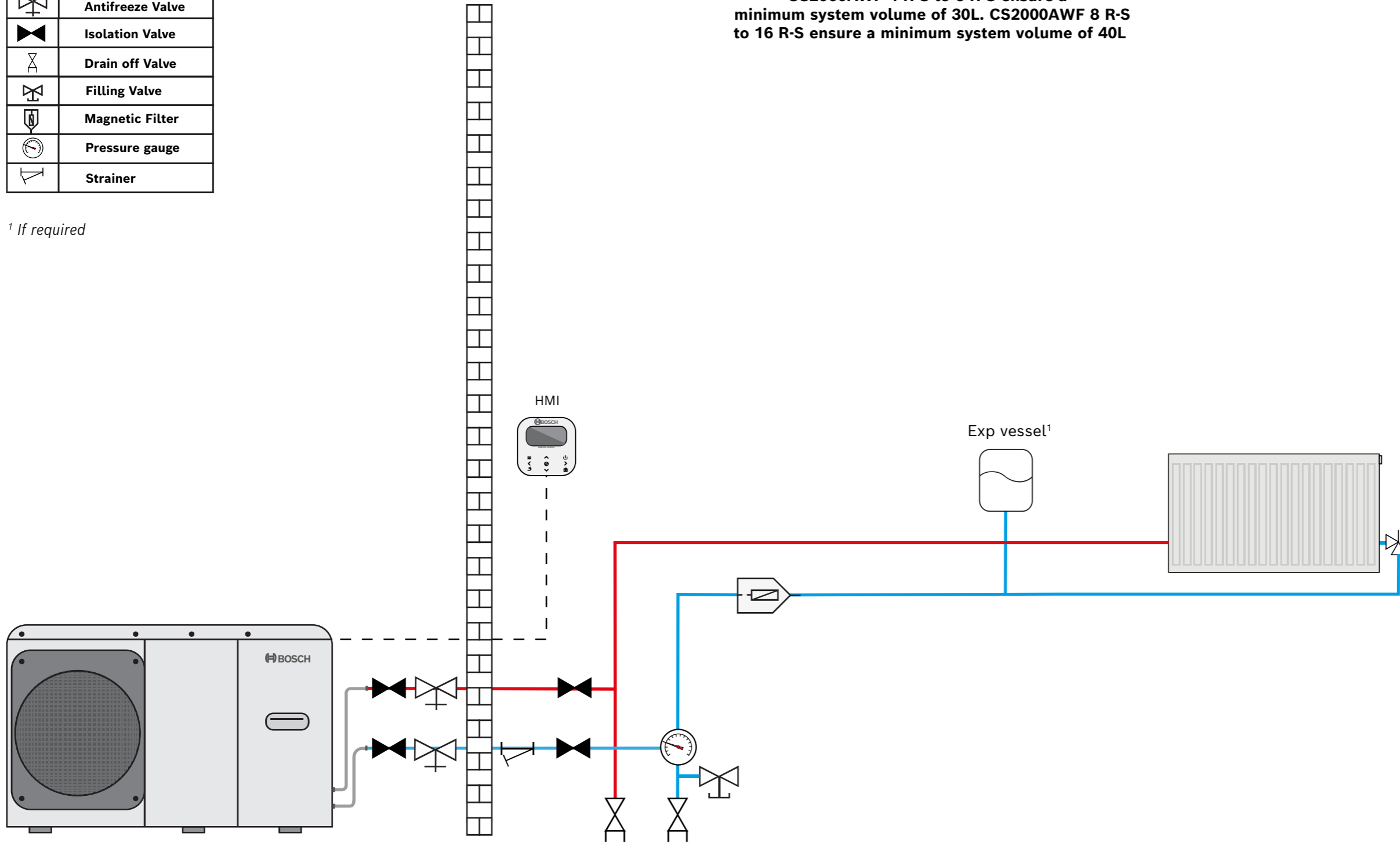

All electrical work should be carried out by a registered engineer. Wiring must comply with the latest IET wiring regulations.

Isolate the mains electricity supply before starting any work and observe all relevant safety precautions. Refer to all relevant product installation manuals for safety and installation instructions.

Whilst it is always our intention to fully assist, it is essential to recognise that all information given by the company is provided in good faith and based upon the information available. Connection labels may not match those of the products installed on site. We recommend that advice should always be checked with your installer, electrician or the manufacturer of the product in question. Consequently, the company cannot be held responsible for any liability relating to the use or repetition of such information or part thereof. In addition, whilst making every reasonable effort to monitor the performance and quality of our supply, installation and service network, we do not accept responsibility for the workmanship or operation of any third party company.

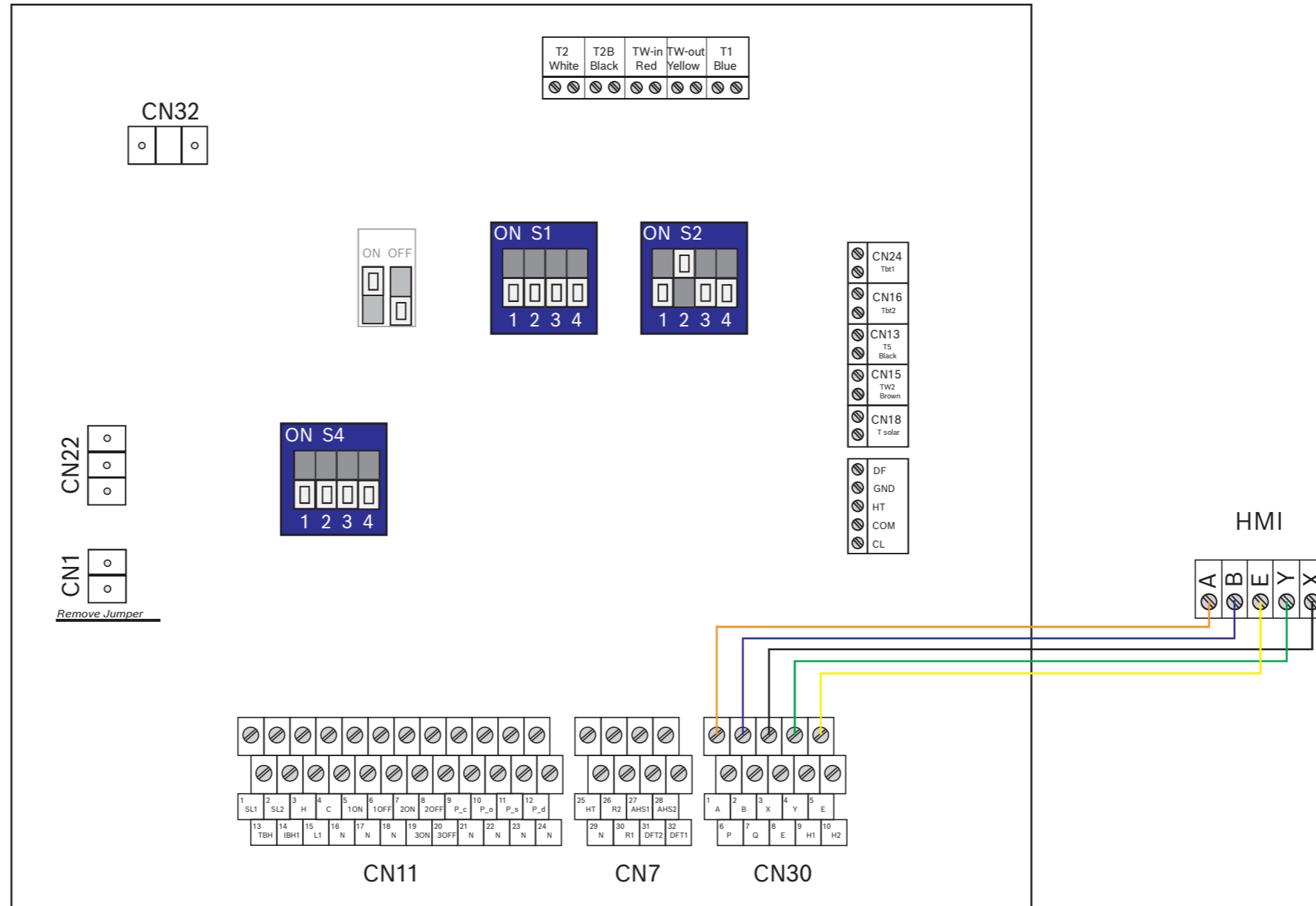

All electrical work should be carried out by a registered engineer. Wiring must comply with the latest IET wiring regulations.

Isolate the mains electricity supply before starting any work and observe all relevant safety precautions. Refer to all relevant product installation manuals for safety and installation instructions.

Whilst it is always our intention to fully assist, it is essential to recognise that all information given by the company is provided in good faith and based upon the information available. Connection labels may not match those of the products installed on site. We recommend that advice should always be checked with your installer, electrician or the manufacturer of the product in question. Consequently, the company cannot be held responsible for any liability relating to the use or repetition of such information or part thereof. In addition, whilst making every reasonable effort to monitor the performance and quality of our supply, installation and service network, we do not accept responsibility for the workmanship or operation of any third party company.

For further information or assistance please contact:
 Email: system.design@uk.bosch.com Tel: 01905751464



Key	Description
	Antifreeze valve
	T1, T5, Tbt1 sensors
	Isolation valve
	Drain off valve
	Filling valve
	Three port valve
	Magnetic filter
	Non return valve
	3rd Party controls
	Pump
	Pressure gauge
	Strainer
	Two port valve

¹ If required

CS2000AWF 4 R-S to 6 R-S ensure a minimum system volume of 30L. CS2000AWF 8 R-S to 16 R-S ensure a minimum system volume of 40L

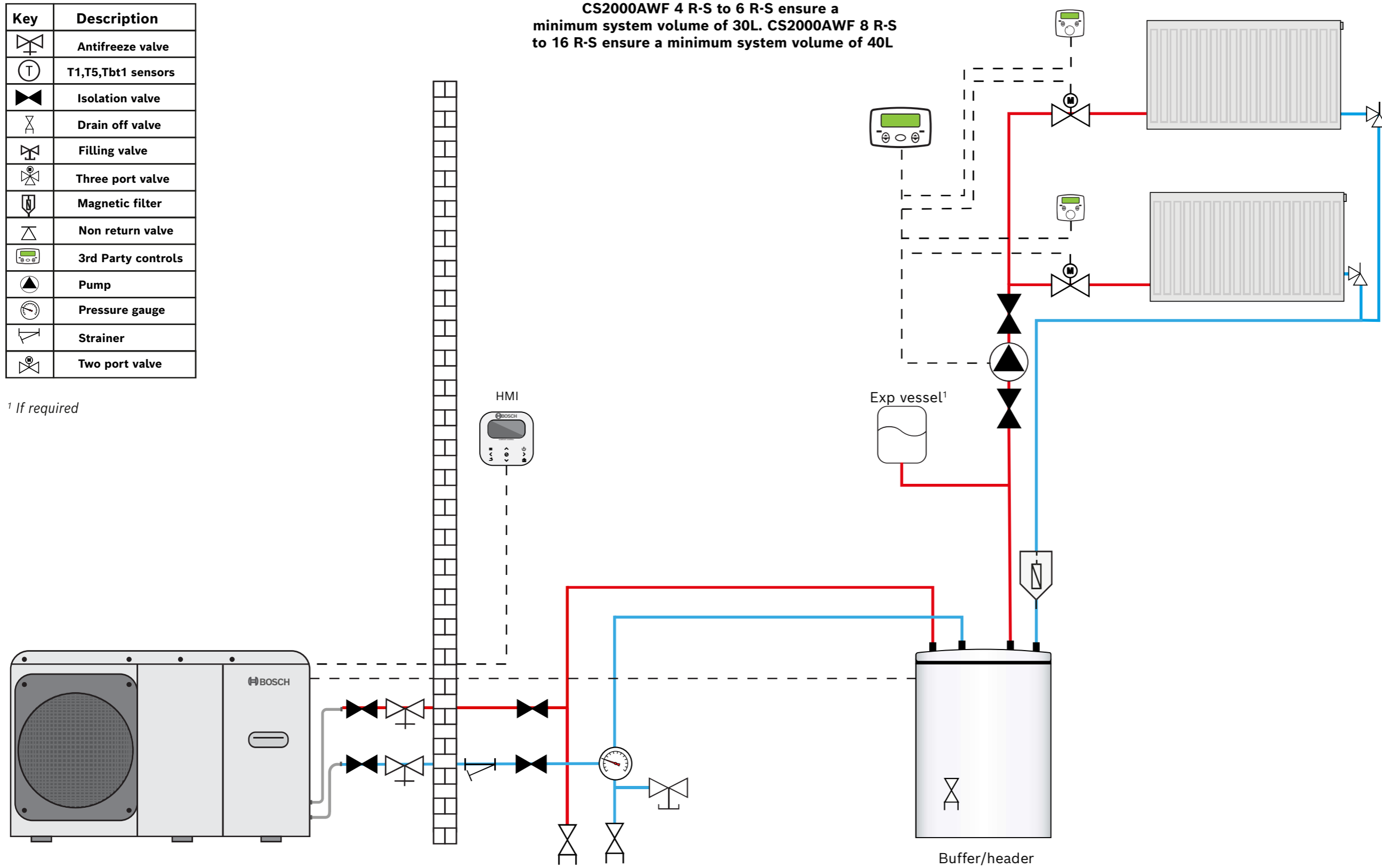

All electrical work should be carried out by a registered engineer. Wiring must comply with the latest IET wiring regulations. Isolate the mains electricity supply before starting any work and observe all relevant safety precautions. Refer to all relevant product installation manuals for safety and installation instructions. Whilst it is always our intention to fully assist, it is essential to recognise that all information given by the company is provided in good faith and based upon the information available. Connection labels may not match those of the products installed on site. We recommend that advice should always be checked with your installer, electrician or the manufacturer of the product in question. Consequently, the company cannot be held responsible for any liability relating to the use or repetition of such information or part thereof. In addition, whilst making every reasonable effort to monitor the performance and quality of our supply, installation and service network, we do not accept responsibility for the workmanship or operation of any third party company.

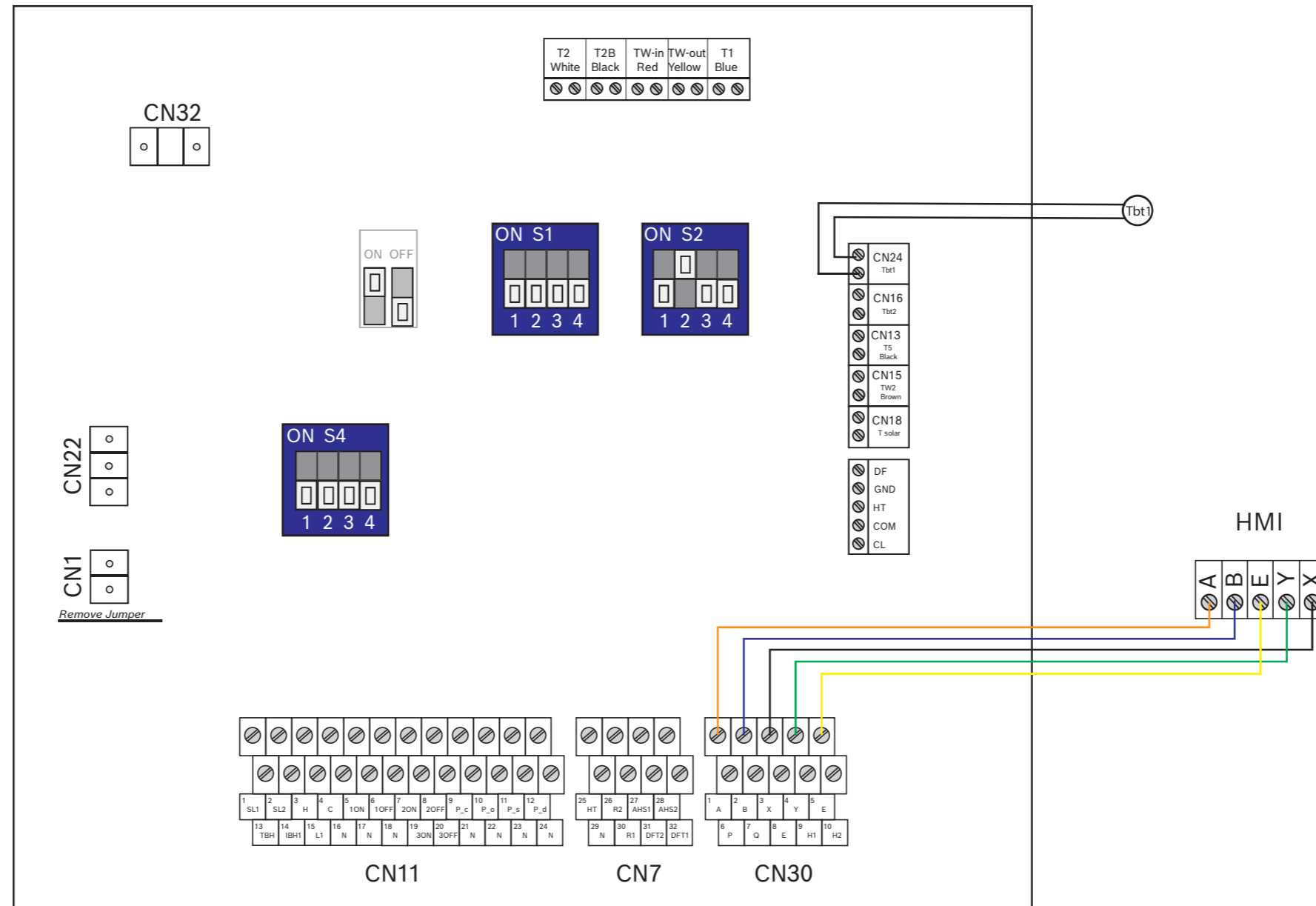

All electrical work should be carried out by a registered engineer. Wiring must comply with the latest IET wiring regulations.

Isolate the mains electricity supply before starting any work and observe all relevant safety precautions. Refer to all relevant product installation manuals for safety and installation instructions.

Whilst it is always our intention to fully assist, it is essential to recognise that all information given by the company is provided in good faith and based upon the information available. Connection labels may not match those of the products installed on site. We recommend that advice should always be checked with your installer, electrician or the manufacturer of the product in question. Consequently, the company cannot be held responsible for any liability relating to the use or repetition of such information or part thereof. In addition, whilst making every reasonable effort to monitor the performance and quality of our supply, installation and service network, we do not accept responsibility for the workmanship or operation of any third party company.

For further information or assistance please contact:
 Email: system.design@uk.bosch.com Tel: 01905751464



Key	Description
	Antifreeze valve
	T1, T5, Tbt1 sensors
	Isolation valve
	Drain off valve
	Filling valve
	Three port valve
	Magnetic filter
	Non return valve
	3rd Party controls
	Pump
	Pressure gauge
	Strainer
	Two port valve ³
	Immersion heater ³
	PRV ³

CS2000AWF 4 R-S to 6 R-S ensure a minimum system volume of 30L.

CS2000AWF 8 R-S to 16 R-S ensure a minimum system volume of 40L.

To calculate minimum system volume for a cascade use the formula below:

$$V(\text{cas}) = \text{Vol}(\text{min}) \text{ of 1 unit} + (\text{units in cascade} \times \text{Vol}(\text{min})/2)$$

Eg. CS2000AWF (6kW) In a 4 unit cascade:
 $V(\text{cas}) = 30\text{L} + ((4 \times 30)/2)$ so $V(\text{cas}) = 90\text{L}$

¹ If required

² Immersion heater required for disinfection. If not connected to the heat pump it must be wired to an external time clock

³ Supplied with cylinder.

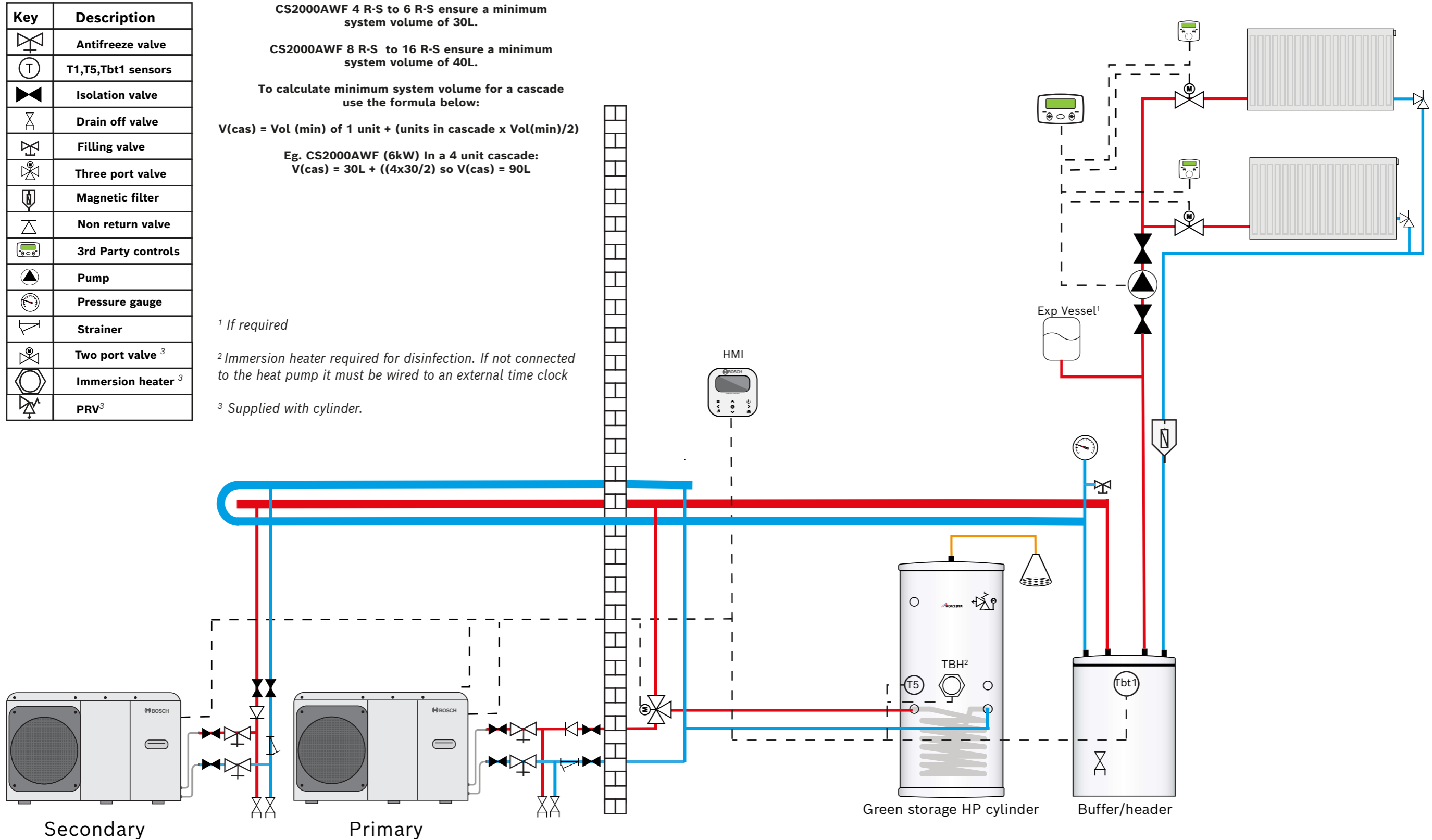

All electrical work should be carried out by a registered engineer. Wiring must comply with the latest IET wiring regulations.

Isolate the mains electricity supply before starting any work and observe all relevant safety precautions. Refer to all relevant product installation manuals for safety and installation instructions.

Whilst it is always our intention to fully assist, it is essential to recognise that all information given by the company is provided in good faith and based upon the information available. Connection labels may not match those of the products installed on site. We recommend that advice should always be checked with your installer, electrician or the manufacturer of the product in question. Consequently, the company cannot be held responsible for any liability relating to the use or repetition of such information or part thereof. In addition, whilst making every reasonable effort to monitor the performance and quality of our supply, installation and service network, we do not accept responsibility for the workmanship or operation of any third party company.

For further information or assistance please contact:

Email: system.design@uk.bosch.com Tel: 01905751464



Primary

Secondary

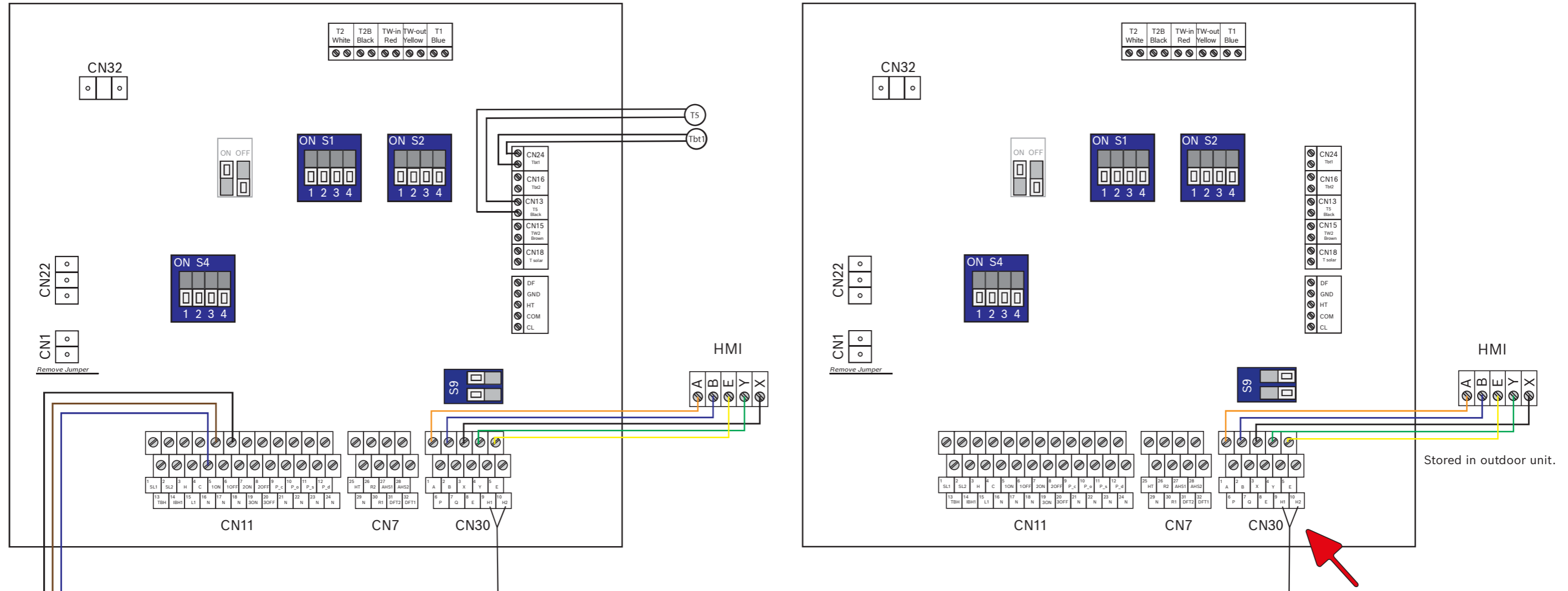

If a third party diverter valve is used wiring and orientation may differ. Seek advice for compatible products

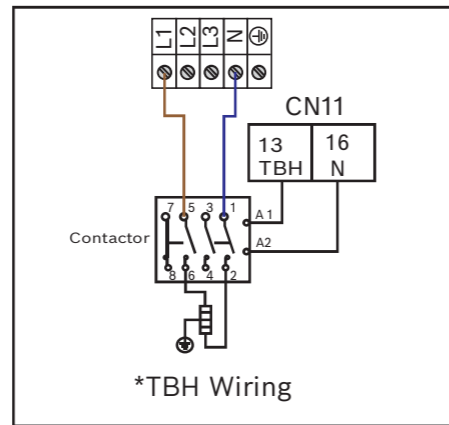

*Wired through a contactor (external power source)

Shielded cable to be used for communication (Shielding must be earthed)

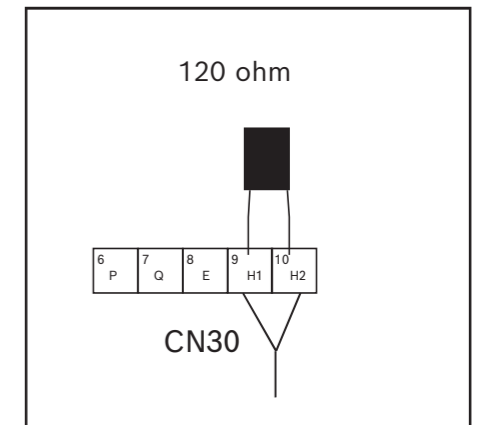

*Connect 120 ohm resistor provided to the final unit in cascade.

All electrical work should be carried out by a registered engineer. Wiring must comply with the latest IET wiring regulations. Isolate the mains electricity supply before starting any work and observe all relevant safety precautions. Refer to all relevant product installation manuals for safety and installation instructions. Whilst it is always our intention to fully assist, it is essential to recognise that all information given by the company is provided in good faith and based upon the information available. Connection labels may not match those of the products installed on site. We recommend that advice should always be checked with your installer, electrician or the manufacturer of the product in question. Consequently, the company cannot be held responsible for any liability relating to the use or repetition of such information or part thereof. In addition, whilst making every reasonable effort to monitor the performance and quality of our supply, installation and service network, we do not accept responsibility for the workmanship or operation of any third party company.